

**Lecture Notes on
UTILIZATION AND ENERGY TRACTION**



**5TH SEMESTER DIPLOMA (EE)
SUBJECT CODE: TH-3**



PREPARED BY

HRUSHIKESH NAYAK

GOVERNMENT POLYTECHNIC, KENDRAPARA

Department of Electrical Engineering

Derabishi , Odisha 754289

www.gpkendrapara.org

Syllabus of UNIT –I:**ELECTRIC DRIVES:**

Type of electric drives, choice of motor, starting and running characteristics, speed control, temperature rise, particular applications of electric drives, types of industrial loads, continuous, intermittent and variable loads, load equalization.

DRIVE: A drive is one, which provides mechanical energy to the machine. There are different types drives namely

- (a) Diesel engine drives
- (b) Electric drives e.t.c.

ELECTRIC DRIVE: An electric drive is defined as a form of machine equipment designed to convert electric energy into mechanical energy and provide electrical control of this process.

ADVANTAGES AND DISADVANTAGES OF ELECTRIC DRIVE OVER OTHER DRIVES:**ADVANTAGES:**

1. The electric system is clean because there is no fuel is required for electric drive and it is free from air pollution.
2. The cost of the electric drive is very less compared to the other drives.
3. In electric drives remote control operation is possible where as in other drives it is not possible.
4. Speed control is possible only by means of electric drives.
5. Electric drives have flexibility in installation.
6. The maintenance required for the electric drives is less and of low cost.
7. Electric drives give long life operation.
8. The installation and maintenance charges are also less for electric drives.
9. Electric drives occupy less space compared to other drives.
10. The efficiency of electric drives is also high when compared to other drives.

DISADVANTAGES:

1. In the case of the failure of the supply, the electric drive comes to rest position which may paralyze the whole system.
2. The application of the electric drive system is limited to electric field area only. i.e electric drive are not used where the supply is not available.

3. In the case of the faults like short circuits, break down of overhead conductors the electric drive system may get damaged and lead to several problems.

FACTORS GOVERNING SELECTION OF ELECTRIC MOTORS:

The basic elements of the electric drive are electric motor, the transmission and the electrical control system. Electric drive is becoming more and more popular for its simplicity, easy and smooth control, reliability and long life. Here the electric motor is very important one in the drive equipment. Now adays there are different types of motors are available with different features. So we have to select the motor as per our requirements. Some factors are to be considers while selecting the motor in the drives. Those factors are as fallows.

1. Nature of the electric supply.
2. Type of drive.
3. Nature of load.
4. Electrical characteristics.
 - (a) Operating or Running characteristics.
 - (b) Starting characteristics.
 - (c) Speed control.
 - (d) Breaking characteristics.
5. Mechanical considerations.
 - (a) Type of enclosures.
 - (b) Type of bearings.
 - (c) Type of transmission for drive.
 - (d) Noise level.
 - (e) Heating and cooling time constants.
6. Service capacity and rating.
 - (a) Requirement for continuous, intermittent or variable load cycle.
 - (b) Pull-out torque and overload capacity.
7. Appearance.
8. Cost.
 - (a) Capital or initial cost.
 - (b) Running cost.

1. Nature of the electric supply:

The electric supply available may be 3-phase a.c. or single phase a.c. or d.c.

In case of three phase a.c. supply is available, polyphase induction motors, squirrel cage type for small ratings and slip ring type for higher ratings may be used. In case where speed variation is required these can not be used, so pole changing motors or motors with stepped pulleys may be used. where accurate control of speed is required, scharge motors may be used. Use of single phase motors is limited to small loads only because of their limited outputs.

D.C. motors are not used so widely as a.c. motors. There are several reasons for this, some of those reasons are given below.

1. Additional equipment is required for converting existing a.c. supply into d.c. supply.
2. D.C. motors have commutators that are subject to trouble and resulting in sparking, brush wear, arc over and the presence of moisture and destructive fumes in the surrounding air.
3. D.C. motors are generally more expensive than a.c. machines for similar working conditions.

In some cases, such as in electric excavators, steel mills and cranes the speed control is important so dc supply is used by converting a.c. supply in to d.c. supply.

2. TYPES OF ELECTRIC DRIVES:

The various types of electric drives used in industry may be divided into three types. They are

1. Group drive
2. Individual drive
3. Multi-motor drive

1. Group Drive: The group drive is a drive in which a single electric motor drives the group of working machines. It comprises of a single lengthy shaft, to the shaft the different working machines are attached by means of pulleys and conveyor belts. Sometimes group drive is also known as LINE SHAFT DRIVE.

Group drive is often used in industries where successive operations are required like car manufacturing industries e.t.c.

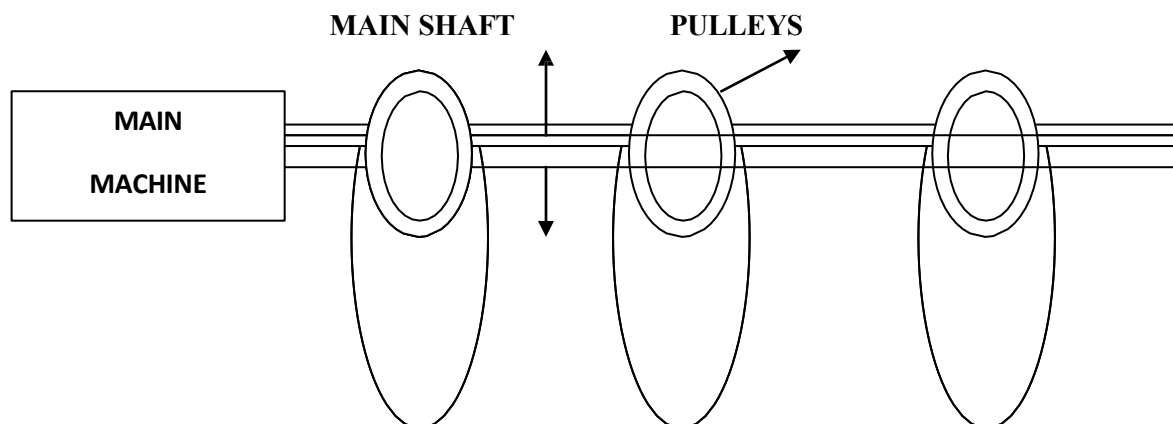

Advantages:

1. In group drive we require one machine with high capacity for to control the group of machines. i.e. here the cost of the one machine with high capacity is less than the number of machines. i.e. cost of a single 10HP motor is very less compared to 10 number of 1HP motors.
2. Different speeds can be obtained by providing pulleys of different diameters.

Disadvantages:

1. In group drive speed control of individual machine is difficult using stepped pulleys, belts e.t.c.
2. Owing to the use of line shafting pulleys and belts group drive does not give good appearance and is also less safe to operate.
3. The possibility of installation of additional machines to the existing system in group drive is limited.
4. If at a certain instance all the machines are not in operation , then the motor will at low capacity and therefore operation efficiency will be low.
5. If a fault occurs in the main machine then all the operations will be effected.

3. **Individual drive:** In individual drive a single electric motor is used to drive one individual machine. i.e In individual drive each working machine has the individual main machine.

Example: single-spindle drilling machines and various types of electrical hand tools and simple types of metal working tools.

Advantages:

1. Installation of individual drive is easy.
2. If a fault is occurred in one main machine then the whole operations are not effected because it has individual main machines.
3. Each main machine can be effectively utilized at rated capacity.
4. Full control and desired operation of each machine is obtained because of different machines are driven with their respective individual drive.
5. Machines can be located at convenient places

Disadvantages:

1. Cost is high because in this type of drive the number of machines required is high.
2. More space is required because of each working machine has its individual main machine.

3. **Multimotor drive:** It consists of several individual drives each of which serves to operate one of many working members.

(OR)

Multi-motor drives means the number of operations are required to perform a task.

Example: The operation of CRANE.

3. Nature of the load:

The loads may be divided according to the speed-torque characteristics in to the following categories.

- (i) Loads required constant torque at all speeds, as shown by the horizontal line 1 in the following figure. Such loads are cranes during hoisting, hoist winches, machine tool feed mechanisms, in piston pump operating against the pressure head.
- (ii) Loads requiring torque which may increase in direct proportion to the speed as shown by straight line 2 in figure.

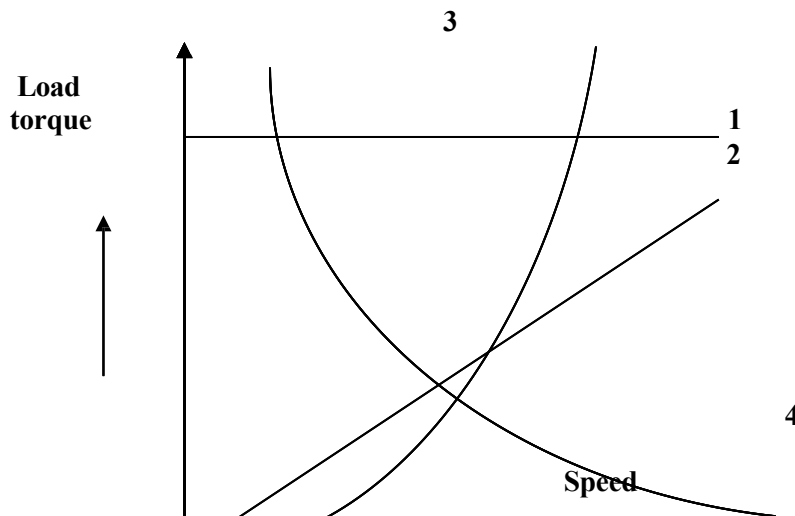

(iii) Loads requiring torque which may increase with the square of speed. As shown by the curve 3 in the above figure. Such loads are blowers, fans, centrifugal pumps, ship propellers e.t.c.

(iv) Loads requiring torque which may decrease with the increase in the speed as shown by the curve 4 in the above figure. Boring machines, milling machines and other types of metal cutting machines are examples of such loads.

4. Electrical characteristics:

(a) Running characteristics or operating characteristics:

While studying electrical behavior of a machine under normal operating conditions, the speed-torque characteristic, speed-current characteristic, and torque-current characteristic, losses, efficiency, magnetizing current and power factor at various loads are to be kept in the view. The last two factors i.e. magnetizing current and power factor are to be considered in case of a.c. motors.

Running characteristics of d.c. motor:

$$E_b = V - I_a R_a \quad \longrightarrow \quad (1)$$

$$E_b = \frac{Z\phi NP}{60A} \quad \longrightarrow \quad (2)$$

From equation 1 and 2

$$E_b \propto \phi N$$

$$N \propto \frac{E_b}{\phi}$$

$$\text{i.e } N \propto \frac{V - I_a R_a}{\phi}$$

Speed-current characteristics:**case 1: for dc shunt motor:**

$$N \propto \frac{V - I_a R_a}{\phi}$$

In shunt motor, ϕ is maintained to be constant since DC shunt motor is a constant speed motor. If V is also maintained to be constant then the speed- current characteristics is obtained as shown in the following figure.

The dc shunt motor must be started under light load condition or no-load condition. Because if we started at full load condition the current will be maximum and then it may damage the motor windings and also it has low starting torque.

Applications:

1. Conveyer belts.
2. Centrifugal pumps.
3. Reciprocating pumps.
4. Grinders.
5. Polishers.
6. Small printing presses.
7. paper making machines.
8. Metal cutting machines.

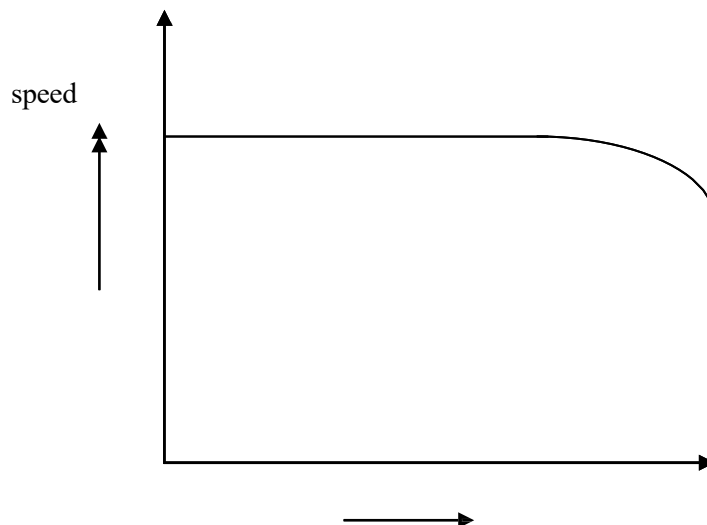

current (I_a)

figure: speed-current characteristics of dc shunt motor

case 2: for dc series motor:

$$N \propto \frac{E_b}{\phi}$$

$$\text{i.e } N \propto \frac{V - I_a R_a}{\phi}$$

$$\text{at constant voltage } N \propto \frac{1}{\phi}$$

$$\text{i.e } N \propto \frac{1}{I_a} \quad (\text{since } \phi \propto I_a)$$

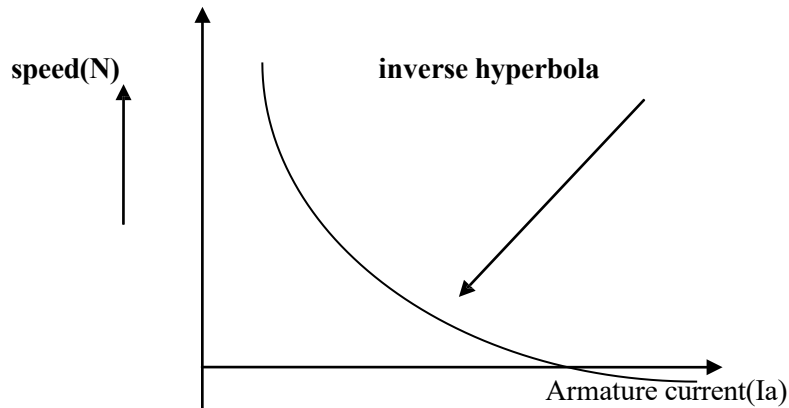

A dc series motor should always be started at full load. Because if it is started at no load (less I_a) the speed is high and the motor may break.

Applications:

Electric traction

case 3: for dc compound motor:

cumulative compound:

$$\phi = \phi_{sh} + \phi_{sc}$$

$$N \propto \frac{1}{\phi}$$

differential compound:

$$\phi = \phi_{sh} - \phi_{sc}$$

$$N \propto \frac{1}{\phi}$$

ϕ is maximum then N is low

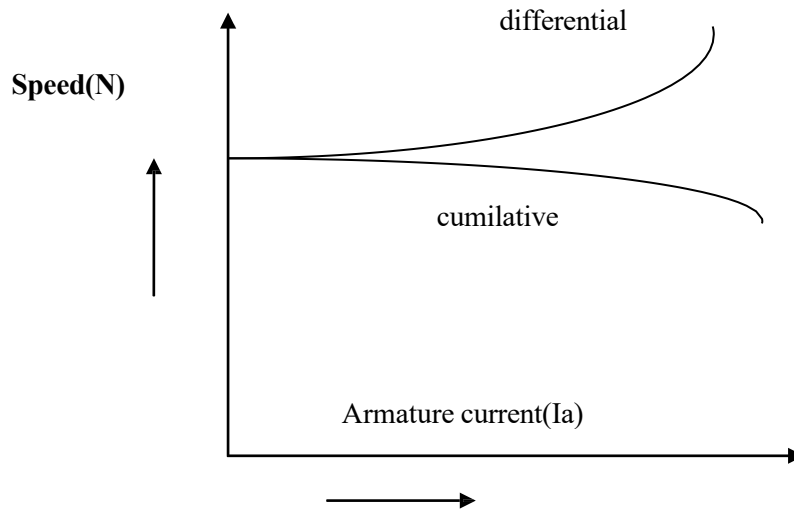

The cumulative compound motors are used in the driving machines. Which are subjected to the sudden application of heavy loads. These motors are used where a large starting torque is required.

Applications: Rolling mills

In differential compound motor the speed remains constant and sometimes increase with increase in the load. This motor may rotate in opposite direction at high loads that is why this motor is seldom used practically.

Torque-Current Characteristics:

In all d.c. motors torque is given by

$$T = \frac{\phi Z P I_a}{2\pi A}$$

$$T \propto \phi I_a$$

case 1: for dc shunt motor:

for a dc shunt motor flux is constant ($\phi = k$)

$$T \propto I_a$$

$$T = k I_a$$

In dc shunt motor it is observed that the torque varies directly as the load current is varying. Hence the characteristics follows the linear law.

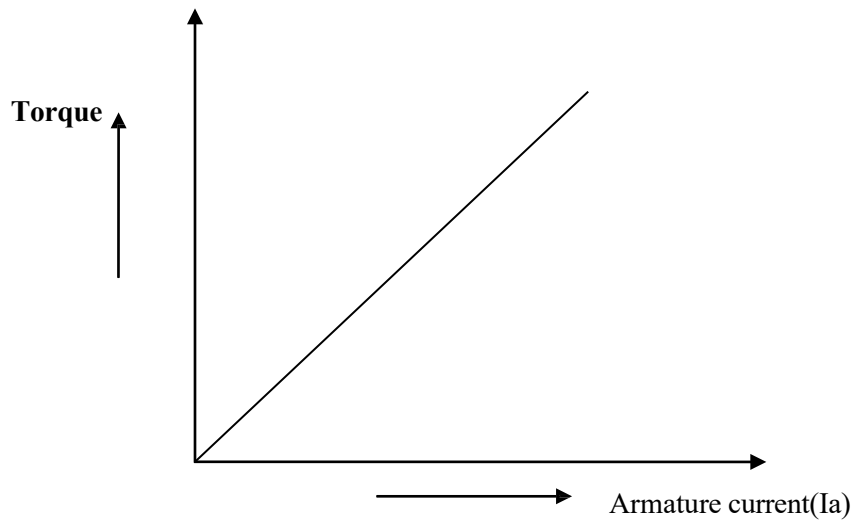

case 2: for dc series motor:

for a dc series motor

$$T \propto \phi I_a$$

$$\phi \propto I_a$$

$$\text{Hence } T \propto I_a^2$$

As we know a dc series motor has high starting torque. So, therefore initially at starting $\phi \propto I_a$ and $T \propto I_a^2$.

After sometime interval the core gets saturated and at that instant $T \propto I_a$

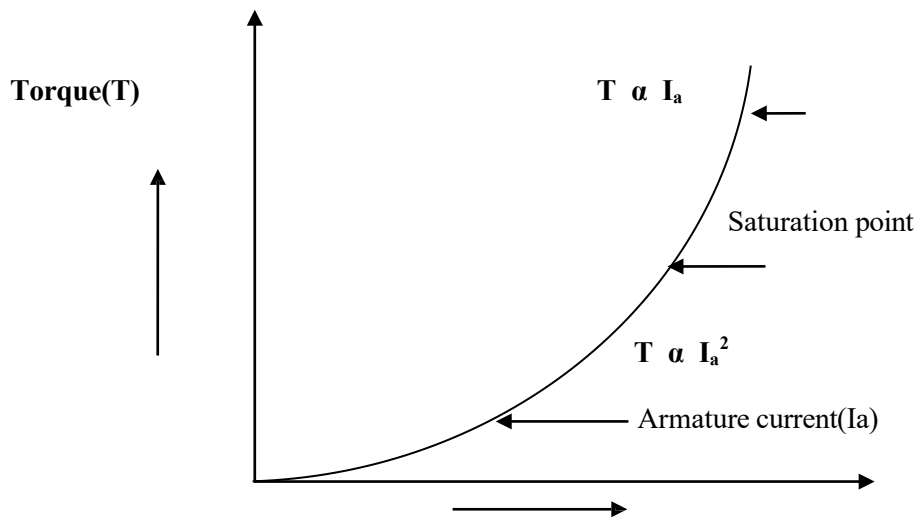

case 2: for dc compound motor:

In cumulative compound motor flux is more, hence torque developed is more. Where as in differential compound motor flux is less and hence torque developed is less.

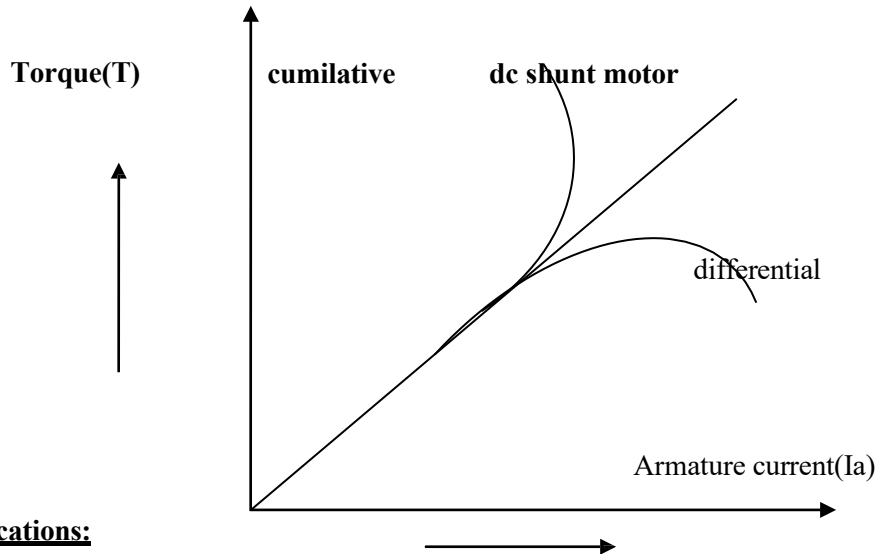

Applications:

Cumulative compound motors are used in driving machines. Which are subjected to sudden application of heavy loads such as in rolling mills. This type of motor is also used, when high starting torque is required such as in cranes.

Speed-Torque characteristics:

In dc motors

$$T \propto \phi I_a$$

$$N \propto \frac{E_b}{\phi}$$

i.e $N \propto \frac{V - I_a R_a}{\phi}$

case 1: for dc shunt motor:

In a dc shunt motor when the supply voltage is constant the field flux and armature flux is also constant and speed of the motor mainly depends upon the armature current. The speed decrease with the increase in armature current.

Hence T-N characteristics of a dc shunt motor will be straight line as shown in the following figure.

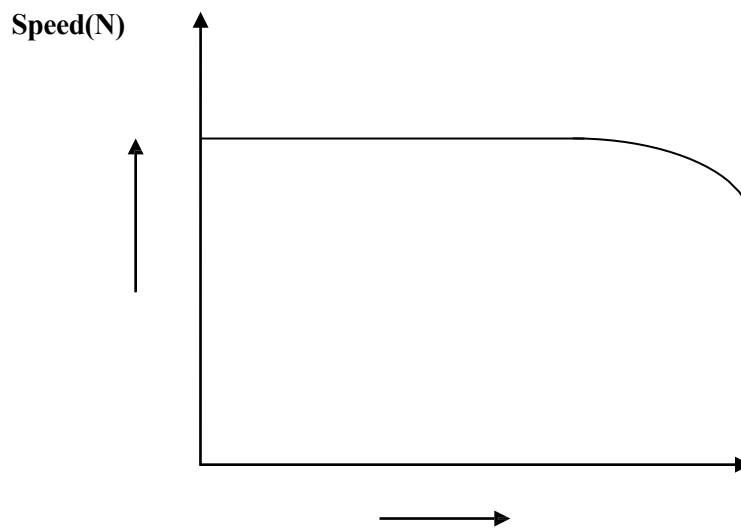

Case 2: for dc series motor:

As the current increases the torque also increases, where as the speed falls. Hence it is observed from the characteristics during starting the torque is less and the speed is dangerously high. The motor must always be started on full load.

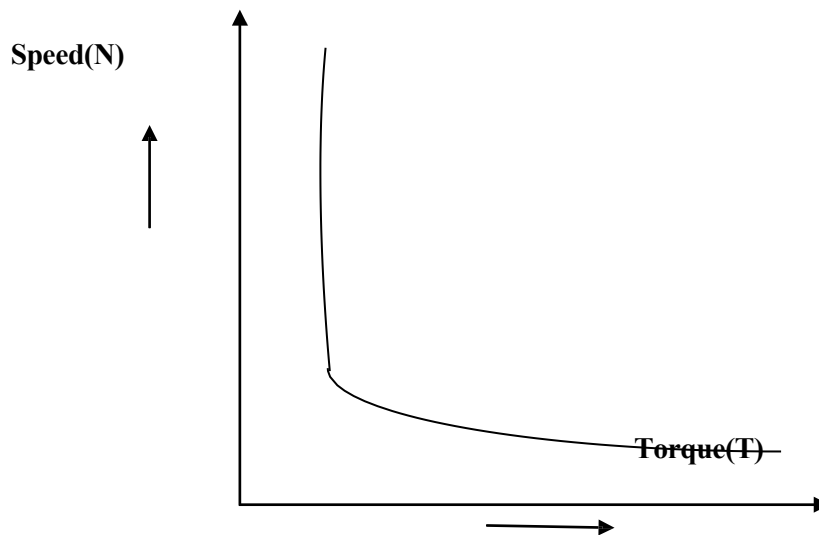

case 2: for dc compound motor:

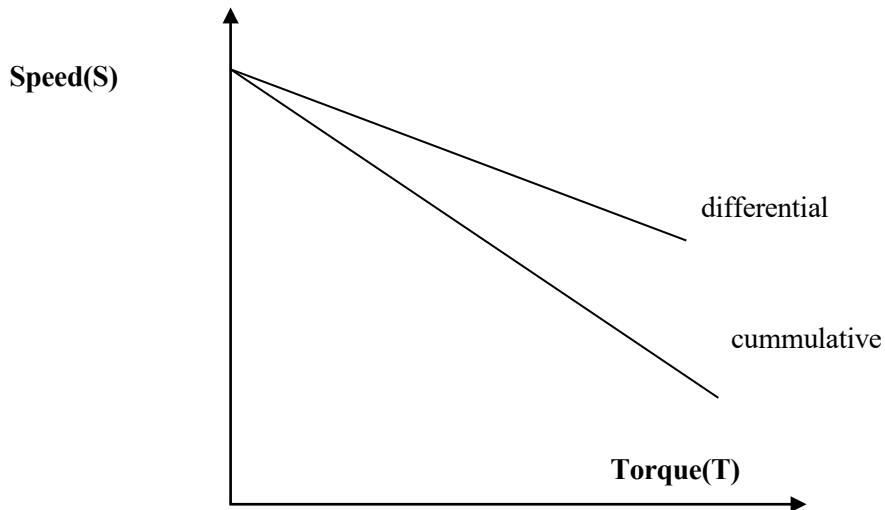

Running characteristics of A.C. motors:

Basically the a.c. motors are classified as follows.

- (i) Synchronous motors
- (ii) Induction motors

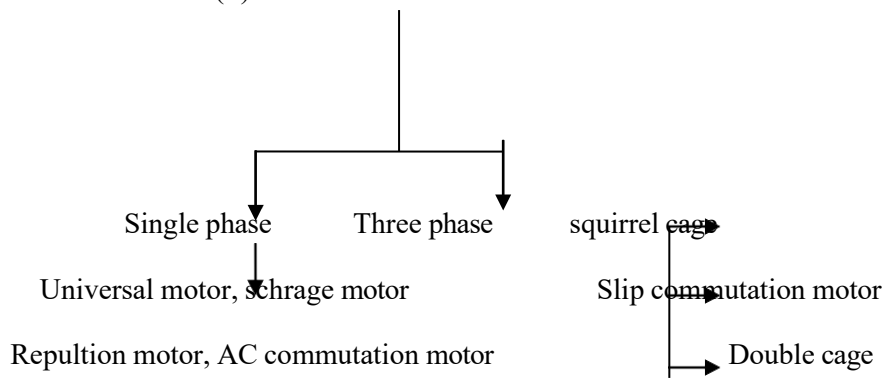

Synchronous motor:

It is the motor which always runs at constant speed known as synchronous speed.

1. The speed of the motor is independent of load.
2. It is not a self starting motor.
3. The power factor of this motor can be varied by changing its field current.

Applications:

In rolling mills, motor-generator sets, pumps

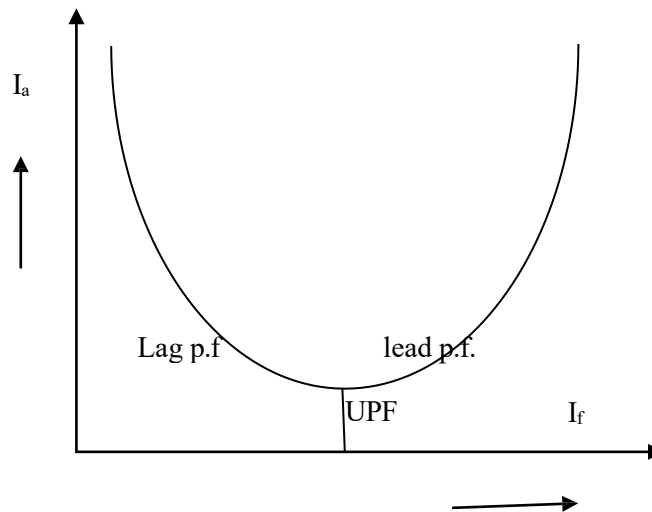
**Single-phase induction motor:**

The constructional features of the single-phase induction motor are similar to that of three-phase induction motor with the exemption that starting is not provided. The speed-torque characteristics are similar to that of three-phase induction motor. As this motors are not self starting separate methods are adopted to make a single phase induction motor self starting. The following are the methods to make it self start

1. Split phase starting.
2. Capacitor starting.
3. Shaded pole starting.
4. Repulsion starting.

The single-phase induction motors are quietly costly and are comparatively bulkey in size, with the help of separate starting devices we can only obtain small amounts of starting torque. Hence single phase induction motor is employed in some of the domestic applications like refrigerators, vaccum cleaners e.t.c.

Three-phase induction motors:

The three phase induction motors are broadly classified in to following types.

1. Squirral cage
2. slip ring
3. double cage

Squirral cage induction motor:

all the above three types of the motorsthe basic equation for the torque is

$$T_s = KV^2 R_L' / (R_1 + R_L')^2 + (X_1 + X_L')^2$$

From the For above equation,

$$K = \text{constant; } V = \text{voltage}$$

R_1 = stator resistance

X_1 = stator reactance

R_L' = rotor resistance referred to stator

X_L' = rotor reactance referred to stator

From the above equations it is clear that starting torque is directly proportional to resistance.

case 1: Squarrel cage induction motor:

In case of squarrel cage induction motor the rotor conductors are short circuited at both ends. Hence there is no chance for including any external resistance. Hence compared to slip ring induction motor this motor has low starting torque, of course the running characteristics of both the motors are same.

case 2: Slip ring induction motor:

For these motors it is possible to include external resistance and hence we can achieve high starting torque.

case 3: Double cage induction motor:

The rotor of this motor consists of two layers of conductors. i.e. outer cage and inner cage. The inner cage has high inductance and low resistance winding where as outer cage has high resistance and low inductance winding. At the time of starting the inner cage offers high inductance to the high frequency currents hence this currents are divided to the outer cage due to which high starting torque is achieved. As soon motors picks up rated speed the frequency of flowing in outer cage if flows in inner cage this reducing the losses.

The power factor of these motors is very less when they are operated at no load or high load. But the power factor improves as the motors tend to near full load. The speed-torque characteristics of all these motors are similar to those of shunt motors.

Applications of squirrel cage induction motor:

To drive pumpsets, machine tools and other operations where constant speed is desired.

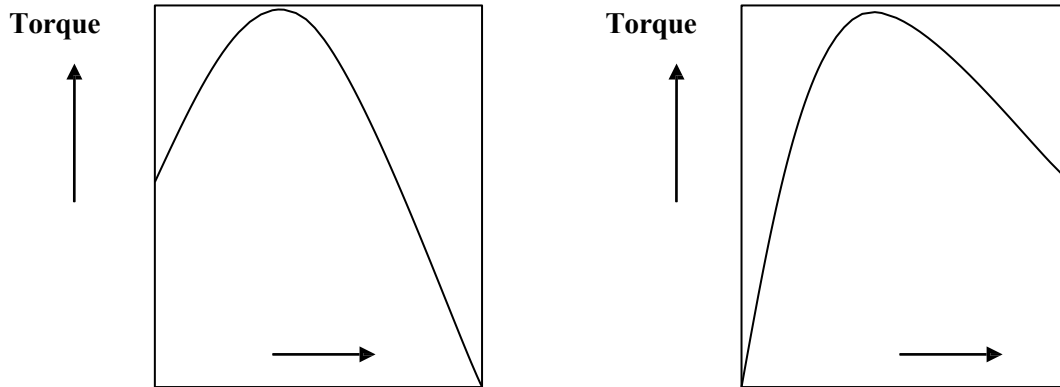
For slip ring induction motor:**Compensated induction motor or no lag motor:**

It is an improved induction motor which always works at unity power factor over wide range of loads. The primary winding is placed on the rotor and secondary winding on the stator. The rotor has an additional winding known as commutator winding whose e.m.f's are collected by the brushes from the commutator and injected into the secondary winding in such a way to improve the power factor.

Repulsion motor:

The construction of this motor is similar to that of series motor except that its armature is short circuited on it self instead of being connected in series with stator, its speed can be adjusted.

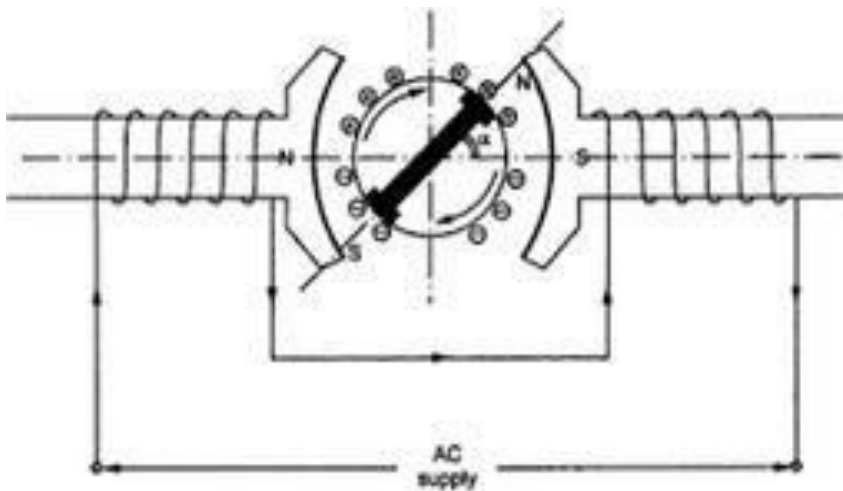
**Schrage motors:**

It is also called brush shifting motor in which power factor correction and speed control are possible. It is an inversed wound rotor induction motor in which stator windings is connected in wye and the primary winding is supplied from three phase supply through slip rings. The torque speed characteristics of this motor are similar to those of a shunt motor.

Applications:

1. High starting torques- lifts, pumps, convayors e.t.c.
2. Adjustable speed- paper mills. Printing presswes e.t.c.

Universal motor:

The motor operates at approximate by the same speed on eighter d.c. or a.c. supply.

It is a series wound motor. The characteristics of this motor are similar to that of dc series motors. These motors are built up in fractional H.P. to one fourth H.P.

Applications:

Sewing machines, table fans, vaccum cleaners, portable drill machine e.t.c.

STARTING CHARACTERISTICS:

The study of starting characteristics of a motor is essential to know weather the starting torque that the motor is capable of developing is sufficient to start and accelerate the motor.

The torque for accelerating depends upon the load torque. The loads which are usually met with, may be divided according to accelerating torque requirements into the fallowing categories:

1. Load requiring very small accelerating torque in comparison with full load torque such as when the motor is to be run light.
2. Load requiring the torque which may increase with speed and it may be proportional to (speed)² as in case of fan.
3. Load having constant load torque at all speeds in case of lifts.
4. When the motors have to start and accelerate against full load torque and in addition to accelerate since some heavy moving parts as in case of rolling mills.

For D.C motors: The torque of a d.c. motor is directly proportional to the product of flux and armature current and is quite independent of speed. Hence in order to having a high starting torque for a given armature current, the flux must be increased to the maximum value possible.

In case of a d.c shunt motor the flux remains constant as the field is connected directly across the constant voltage supply mains and the armature current is controlled by connecting a starting resistance in series with the armature as shown in the figure. The torque, which is directly proportional to the armature current is limited by the maximum allowable starting current.

In case of a d.c series motor the field winding is connected in series with the armature therefore, the current in the series field winding and armature is the same. Since upto saturation point the flux is directly proportional to the current flowing through the field and after saturation point the flux is independent of current and remains almost constant. Therefore, the torque varies as the square of the armature current upto saturation point.

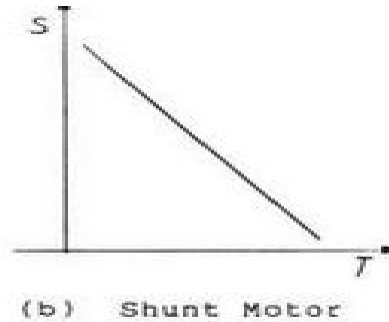
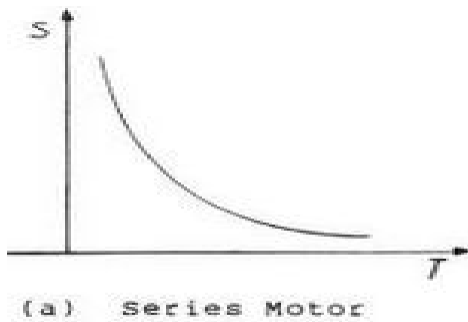

For A.C motors: In case of three phase induction motor

All the above three types of the motors the basic equation for the torque is

$$T_s = KV^2 R_L' / (R_1 + R_L')^2 + (X_1 + X_L')^2$$

From the For above equation,

$K = \text{constant}; V = \text{voltage}$

$R_1 = \text{stator resistance}$

$X_1 = \text{stator reactance}$

$R_L' = \text{rotor resistance referred to stator}$

$X_L' = \text{rotor reactance referred to stator}$

From the above equations it is clear that starting torque is directly proportional to resistance.

The starting torque becomes maximum when the rotor resistance is made equal to the leakage reactance. Since the rotor resistance is not more than 1 or 2 percent of its leakage reactance. Therefore, in order to obtain high starting torque resistance must be inserted in the rotor circuit as start and cutout gradually as the motor picks up speed. The additional resistance in the rotor circuit is not only for high starting torque also for to limit the starting current. This method is useful in case of slip ring induction motor only, in which the external resistance at the starting instant is introduced in the rotor circuit by taking the rotor winding terminals out to the slip rings mounted on the shaft with brushes resting on them.

In case of single phase induction motor the following methods are employed for starting.

Pole shading: A short circuited copper coil is placed round a portion of each pole, and this coil has currents induced in it by transformer action; these cause the flux in that proportion of the pole to lag on the main flux so that the rotating field is produced, enabling the motor to start.

Phase splitting devices: Another method of obtaining a rotating field at starting is to employ a phase splitting devices which produces a two-phase supply so that the motor can be started.

Repulsion motor starting: the repulsion motor has a high starting torque, and in order to be able to combine this with the constant speed torque characteristic of the induction motor, two types of repulsion start induction motor have been developed. One of these employs an ordinary repulsion motor winding on the rotor with a centrifugally

operated device which short circuits all the commutator segments and rises the brushes when the motor reached nearly full speed, thus converting it into a squirrel cage induction motor.

Speed control:

D.C motors:

$$N \propto \frac{V - I_a R_a}{\phi}$$

While selecting a motor for a particular drive special care has to be taken for the speed variations. If we consider the entire range of loads out of which some loads may require constant speed drives, some may require smooth variation on speed and some may require step changes in speed.

Speed control of D.c. motors:

$$N \propto \frac{V - I_a R_a}{\phi}$$

The speed control of dc motors is possible in three ways.

1. By varying field flux.
2. By varying applied voltage.
3. By varying resistance in armature circuit.

1. By varying field flux(ϕ):

The field flux is directly proportional to field current. Hence by varying field current the flux can be varied to obtain the variable speed. The field current can be varied by introducing a variable resistance in the field circuit.

For series motor variable resistance is connected in parallel with field winding as shown in the figure1.

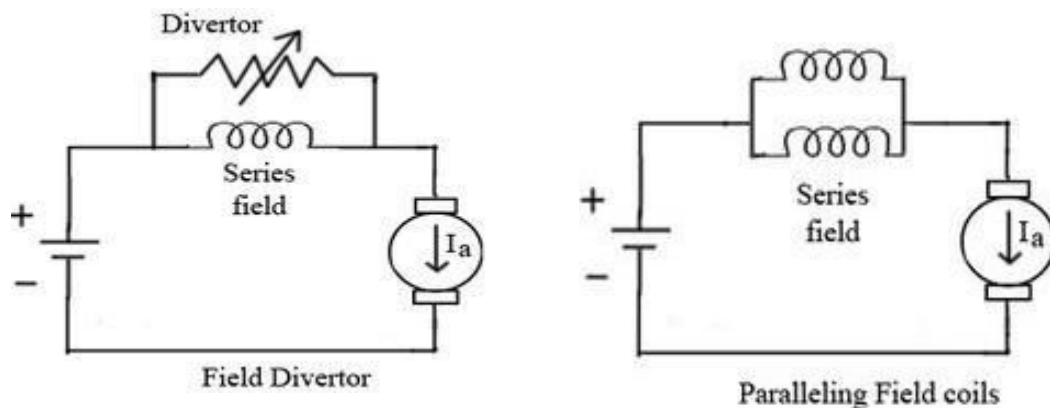

2. By varying applied voltage

By varying the applied voltage of the motor the speed is controlled and another method is by using the tapping field windings as shown in figure2 the speed is controlled in this method by changing the tapping of the field winding the field current can be varied and therefore the speed is varied.

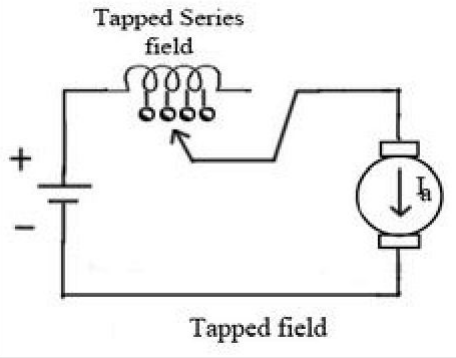

Types of loads:

1. Based on influence of gravity, compression on tension.
 - (a) Active loads (gravity) example: lifts and hoisters.
 - (b) Passive loads (friction) example: mills.

2. Based upon time of operation
 - (a) Continuous and constant loads example: centrifugal pumps
 - (b) Continuous and variable loads example: conveyors, hoisters
 - (c) Pulsating example: reciprocating pumps and textile looms
 - (d) Impact loads example: rolling mills, shearing mills
 - (e) Intermitted loads example: cranes and hoisters

3. Based upon the speed of the motor (shown in the following figure)
 - (a) Constant load torque example: hoisters and cranes
 - (b) Torque \propto speed example: fluid friction
 - (c) Torque \propto speed² example: fans
 - (d) Torque $\propto \frac{1}{(\text{speed})^2}$ example: grinding

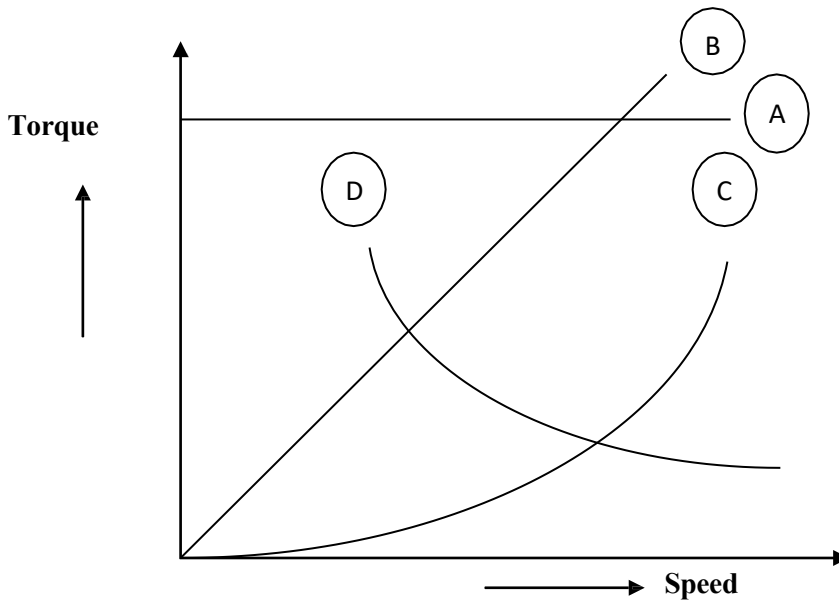

LOAD EQUALISATION:

In many industrial drives, such as in rolling mills, planing machines, electric hammers, reciprocating pumps, the load fluctuates over a wide range. It is desirable to smooth out the fluctuating load, otherwise during intervals of peak load it will draw a heavy current from the supply either producing large voltage drop in the system or requiring cables and wires on heavy section. The process of smoothing out the fluctuating load is known as load equalization. In this process, energy is stored during the interval of light load and given out during the interval of peak load thus power from the supply remains approximately constant.

The most common method of load equalization is by use of fly wheel. During the light load period the fly wheel accelerates and stores the excess energy drawn from the supply and during peak load period the fly wheel decelerates and supplies some of its stored energy to the load in addition to the energy supplied from the supply. Thus the load demand is reduced.

The motors used for such loads should have dropping characteristics, so that the speed may fall with the increase in load and enables the fly wheel to give up its stored energy. For the loads in which the motor has to run in the same direction and is not to be stopped and started frequently, flywheel may be mounted on the motor shaft.

For a reversing drive, such as for colliery winders, the Ward Leonard control system is generally used for reversing and speed control, so flywheel can be mounted on the shaft of the motor-generator.

Syllabus of UNIT –II:

ELECTRIC HEATING AND WELDING:

Advantages and methods of electric heating, resistance heating induction heating and dielectric heating.

Electric welding, resistance and arc welding, electric welding equipment, comparison between A.C. and D.C.

Welding

INTRODUCTION:

When current is passed through a conductor, it gets heated up due to I^2R losses and this heating characteristic of the electric current is being utilized in industrial and domestic appliances.

Heating is required for domestic purposes such as cooking and heating of buildings whereas for industrial purposes and heating is required for melting of metals , hardening and tempering and in welding.

Advantages of electric heating over other systems of heating :

The main advantages of electric heating over other systems of heating (i.e coal, gas, or oil) heating are:

- 1. Economical:** Electric heating is economical as electric furnaces are cheaper in initial cost as well as maintenance cost. It does not require any attention so there is a considerable saving in labour cost over other systems of heating. moreover, the electric energy is also cheap as it is produced on large scale.
- 2. Cleanliness:** Since dust and ash are completely eliminated in electric heating system, so it is clean system and cleaning costs are rendered to a minimum.
- 3. Absence of fuel gases:** Since no fuel gases are produced in this system, the atmosphere around is clean and pollution free.
- 4. Ease of control:** Simple, accurate and reliable temperature of a furnace can be had with the help of manual or automatic devices. Desired temperature can be had in electric heating system which is not convenient in other heating systems.
- 5. Efficiency:** It has been practically found that 75 to 100% of heat produced by electric heating can be successfully utilized as the source can be brought directly to the point where heat is required there by reducing the losses.

6. Automatic protection: Automatic protection against over currents or overheating can be provided through suitable switchgears in electric heating systems.

7. Better working conditions: Electric heating system produces no irritation noise and also the radiation losses are low. Thus working with electric furnaces is convenient and cool.

8. Safety: Electric heating is quite safe and responds quickly.

9. Upper limit temperature: There is no upper limit to the temperature obtainable except the ability of the material to withstand heat.

10. Special heating requirements: Certain requirements of heating such as uniform heating of material or heating of one particular portion of the job without effecting others, heating of non-conducting materials, heating with no oxidation can be met only in electric heating system.

Heating element:

The heating effect of electric current can be produced by passing electric current through

Heating element and the material used for heating element must have following properties.

1. It should have high specific resistance so that a small length of wire ($R = \frac{\rho l}{a}$, $\rho = \frac{Ra}{l}$) is sufficient to produce the required amount of heat.
2. It should have high melting point so that high temperature can be obtained.
3. It should have low temperature co-efficient since for accurate temperature control, the resistance should be nearly constant at all temperature and this is possible only if the resistance does not change with temperature.
4. It should not oxidize at higher temperatures otherwise its life is shortened and needs frequent replacement.

The most commonly used heating elements are either alloy of nickel and chromium or nickel-chromium iron, nickel-chromium-aluminium, nickel-copper. The use of iron reduces the cost but lowers the life of the element.

Causes of failure of heating element

There are so many causes are there for the failure of heating element. Some of them are explained below.

1. **Formation of Hot Spots:** Hot spots are the points in heating element which are at higher temperature than the main body of the element. Hot spots may be due to any of the following causes:
 - (a) High rate of local oxidation may reduce the cross-section of the element wire thereby increasing the resistance at that spot. Thus more heat will be produced locally giving rise to the breakdown of the element.
 - (b) Shielding of element by supports etc. will reduce the local heat loss by radiation and causes a rise of temperature of shielded portion of the element therefore minimum number of supports without producing distortion of the element should be used.
 - (c) Due to too high element temperatures, insufficient support for the element or selection of wrong material, sagging and wrapping of element may result which may causes uneven spacing of sections there by producing hot spots.
2. **Oxidation of intermittency of operation:** At high temperature, oxide scale is formed on the heating element which is continuous and tenacious and is so string that it prevents further oxidation of inner metal of element. However, if the element used quite often the oxide layer is subjected to thermal stresses due to frequent cooling and heating thereby the oxide layer cracks and flakes off exposing further fresh metal to oxidation thereby producing hot spots.
3. **Embrittlement due to grain, growth:** All heating alloys containing iron, tend to form large brittle grains at high temperatures. When cold the elements are very brittle and liable to rupture easily on slightest handling and jerks.
4. **Contamination and corrosion:** Elements may be subjected to dry corrosion produced by their contamination with the gases of controlled atmosphere prevailing in annealing furnaces or fumes from flux used in brazing furnaces or oil fumes produced by heat treatment of components contaminated with lubricant.

Modes of Transfer of Heat:

The heat from one body to another body can be transferred by any one of the following methods.

1. Conduction
2. Convection
3. Radiation

1. Conduction:

In this method, heat travels without the actual movement of particles (molecules). The flow of heat from one part of the body to other part is dependent upon the temperature differences between these parts. It is also applicable when two bodies at different temperatures are joined together. The heated molecules of the substances transfer their heat to the adjacent molecules and this heat flow will invariably take place so long as there is difference in temperature.

For example when one end of solid is heated, the molecules at that end absorb the heat energy and begin to vibrate rapidly when these molecules collide with neighboring molecules, some energy is passed them with in turn begin to vibrate faster and pass some energy to their molecules. Thus heat is transferred from one molecule to another molecule without their actual movement.

If the heat is to be conducted from one object to another object, the following conditions must be met.

1. The objects should be bodily in contact with each other.
2. The temperature of the two bodies should be different i.e. temperature gradient should exist.

Definition of conduction: The process in which heat is transferred from one particle to another in direction of fall of temperature without the actual movement of particles of medium is called conduction.

The rate of conduction of heat along a substance depends upon the temperature gradient and is expressed in $\text{Mj/hr/m}^2/\text{m}/\text{c}^0$ or in watts/cm^2 in case of electric heating.

In a plate of thickness t meters having X-sectional area of its two parallel faces A sq.meters and temperature of two faces is T_1 and T_2 absolute, the quantity of heat transferred through it during T hours is given by

$$Q = \frac{KA}{t} (T_1 - T_2) T$$

Where K is coefficient of thermal conductivity for material in $\text{Mj/hr/m}^2/\text{m}/\text{c}^0$

2. Convection:

Def: The process of heat transference in which heat is transferred from one place to another (from hotter to colder one) by actual movement of particles of medium is called convection.

For example in case of heater used for heating buildings, the air in contact with a heat radiator element in a room receives heat from contact with the element. The heated air expands and rises, cold air flowing into takes place. Thus there is a constant flow of air upwards across the heating elements. Thus in this way the room gets heated up.

A similar action takes place in an electric water heater, a continuous flow of water passing upwards across the immersed heating element, with the result that the whole of the water in the tank becomes hot.

The quantity of heat absorbed from the heater by convection depends mainly upon the temperature of the heating element above the surroundings and upon the size of surface of the heater. It also depends partly on the portion of the heater.

Heat dissipation is given by the following expression

$$H = a (T_1 - T_2) b \text{ w/m}^2$$

Where a, b - constants whose values depends on the heating surface facilities for heating etc.

T_1, T_2 - temperature of the heating surface and fluid in $^{\circ}\text{C}$.

3. Radiation:

Def: The process of transmission of heat in which heat energy is transferred from hotter body to colder body without heating the medium in between is called radiation.

For example we receive energy from the sun by radiation through there in distance of about 150 million Kms between sun and earth.

Rate of heat radiation is given by stefan's law according to which:

$$\text{Heat dissipation } H = 5.72 \times 10^4 K_e \left(\frac{T_1}{1000} - \frac{T_2}{1000} \right)^4$$

Where T_1 - temperature of source of heat in $^{\circ}\text{C}$

T_2 - temperature of substance to be heated in $^{\circ}\text{C}$

K – constant known as radiant efficiency whose value is 1 for single element and 0.5 to 0.8 for several elements placed by side by side.

e – emissivity which is 1 for black body. And 0.9 for resistance heating elements.

Electric heating methods:

Electric heating methods can be classified as:

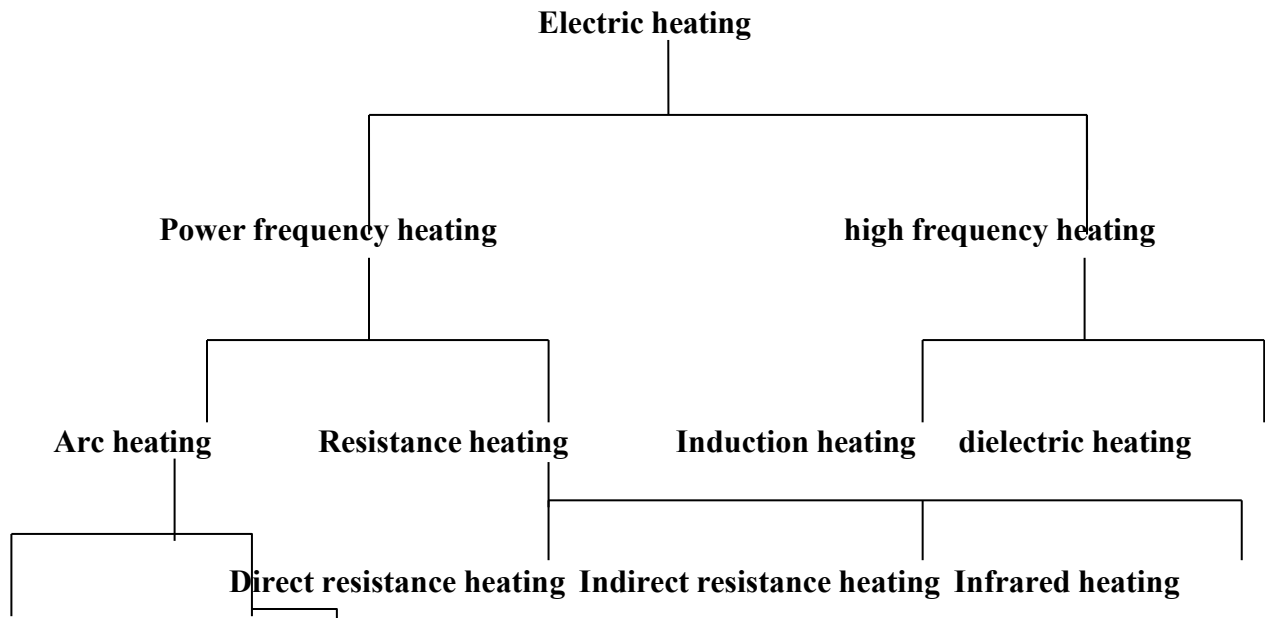

Direct arc heating Indirect arc heating

ARC HEATING:

When a high voltage is applied across in air gap, the air in the gap gets ionized under electrostatic forces and become conducting medium. Current flows in the form of a continuous spark called the arc. A very high voltage is required to establish an arc across the air gap but to maintain an arc small voltage should be sufficient.

Alternatively an arc can also be produced by short circuiting the two electrodes momentarily and then withdrawing them back. Arc between the two electrodes produces heat and has a temperature between 1000°C and 3500°C depending upon the material of electrodes used. The use of this principle may be in *electric arc furnace*.

Usually arc furnaces are of cylindrical shape but recently conical shaped shells have been used due to the advantage of a large surface area per unit volume. Moreover the conical shaped furnace consumes less power, radiation loss and melting time is also reduced.

The arc chamber of the furnace consists of a suitable acid or basic refractory lining supported on a metal frame. Each furnace is provided with charging door and tap hole for introducing the charge and taking out the molten metal. The electrodes project through the top or sides of chamber and are arranged for easy replacement and adjustment. The electrodes used in arc furnace are either made of carbon or graphite. Graphite is mostly preferred however carbon electrodes are used with small furnaces.

The salient points of the two types of electrodes are:

1. **Resistance:** owing to lower resistivity of graphite the size of graphite electrode is reduced to half of the carbon electrode for the same current carrying thus facilitating easy replacement.
2. **Consumption:** graphite begins to oxidize at about 600⁰c whereas carbon at about 400⁰c and thus consumption of graphite electrode is about one half of carbon electrode.
3. **Evenness of heating:** The larger area of carbon electrodes means a greater surface area of charge covered by the arc and consequently a more uniform distribution of heat, on the other hand however the arc is brought nearer to the side of furnaces which tend to shorten the life of refractor lining.
4. **Cost:** Graphite electrodes cost about twice as much per Kg as carbon electrodes so that the savings due to their use largely nullified especially if the process is one in which the electrode consumption is large.

The choice between the two types of electrodes depends upon the application however in general for processes requiring large quantities of electrodes, the carbon electrode is used.

Types of furnaces:

Arc furnaces may be classified into two types.

1. Direct arc furnace.
2. Indirect arc furnace.

1. Direct arc furnace:

In this type of furnace, the arc is formed between the electrodes and the charge as shown in figure 1. In this type of furnace, charge acts as another electrode. There are two carbon or graphite electrodes and the arc is developed at two places.

Since in direct arc furnace, the arc is in direct contact with the charge and heat is also produced by current flowing through the charge itself, the charge can therefore be heated to highest temperature.

In case of single phase arc furnace, two electrodes are taken vertically downward through the roof of furnace to the surface of charge whereas in case of three phase arc furnace three electrodes put at the corners of an equivalent triangle are used which produces three arcs, the charge itself thus forms a star point.

The most common application of this type of furnace is for production of steel. This is advantageous as compared to cupola method for production of steel due to the following reasons.

1. By using this method, purer product can be obtained as refining process can be easily controlled.
2. Arc furnace can operate on 100% steel scrap which is cheaper than pig iron whereas cupola requires a proportion of pig iron in cupola charge.

This is the reason, direct arc furnace even being costlier in initial as well as operating costs is preferred.

2. Indirect arc furnace:

In this type of furnace, the arc is formed between two electrodes above the charge and the heat is transmitted to the charge solely by radiation as shown in figure 2.

The temperature of the charge in the indirect-arc furnace is lower than in the direct-arc furnace, since heat is transmitted to it solely by radiation. As no current flows through the charge there is no inherent stirring action, and the furnace must be rocked mechanically; for this reason a cylindrical shape is adopted, with the electrodes projecting through the chamber at each end along the horizontal axis. This construction limits the number of electrodes to two and arc is produced by bringing the electrodes into solid contact and then with drawing them. Power input is regulated by adjusting the arc length by moving the electrodes.

Due to the indirect heating, the furnace is suitable for comparatively lower melting point such as melting of non-ferrous metals. They are also used in iron foundries where intermittent supply of molten metal is required.

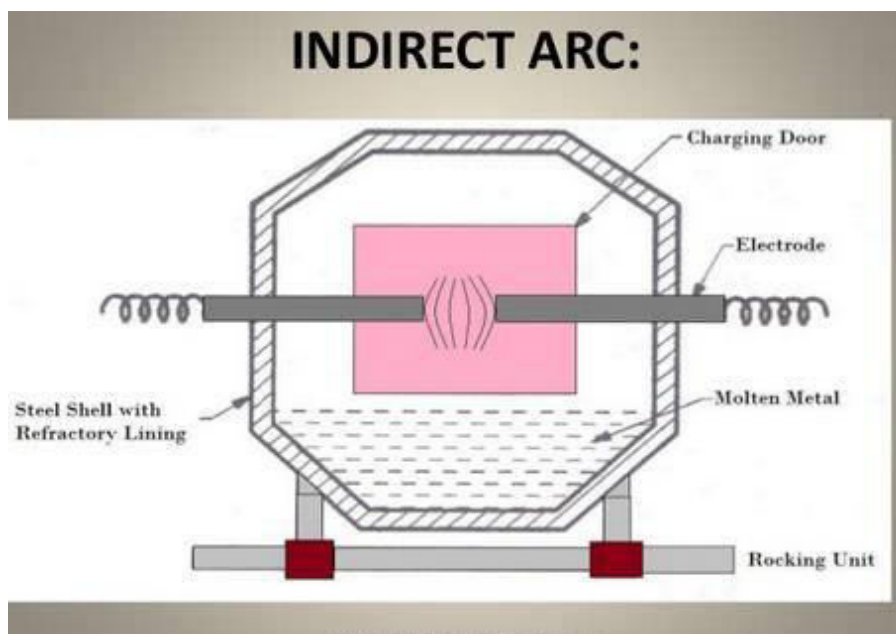

Resistance heating:**Direct Resistance:**

In this method, current is passed through substance to be heated. The resistance offered by the substance to flow of current produces ohmic losses I^2R which results in heating the substance.

In other words, the material to be heated is taken as resistance and current is passed through it. The material may be in form of powder, pieces or a liquid. The electrodes in case of d.c. or single phase a.c. or three electrodes in case of 3-phase a.c. are immersed in the charge and connected to the supply. The current flows through the charge and heat is produced. This method has high efficiency since heat is produced in charge itself.

This method of heating is employed in resistance welding, in electrodes boiler for heating water and in salt bath furnace.

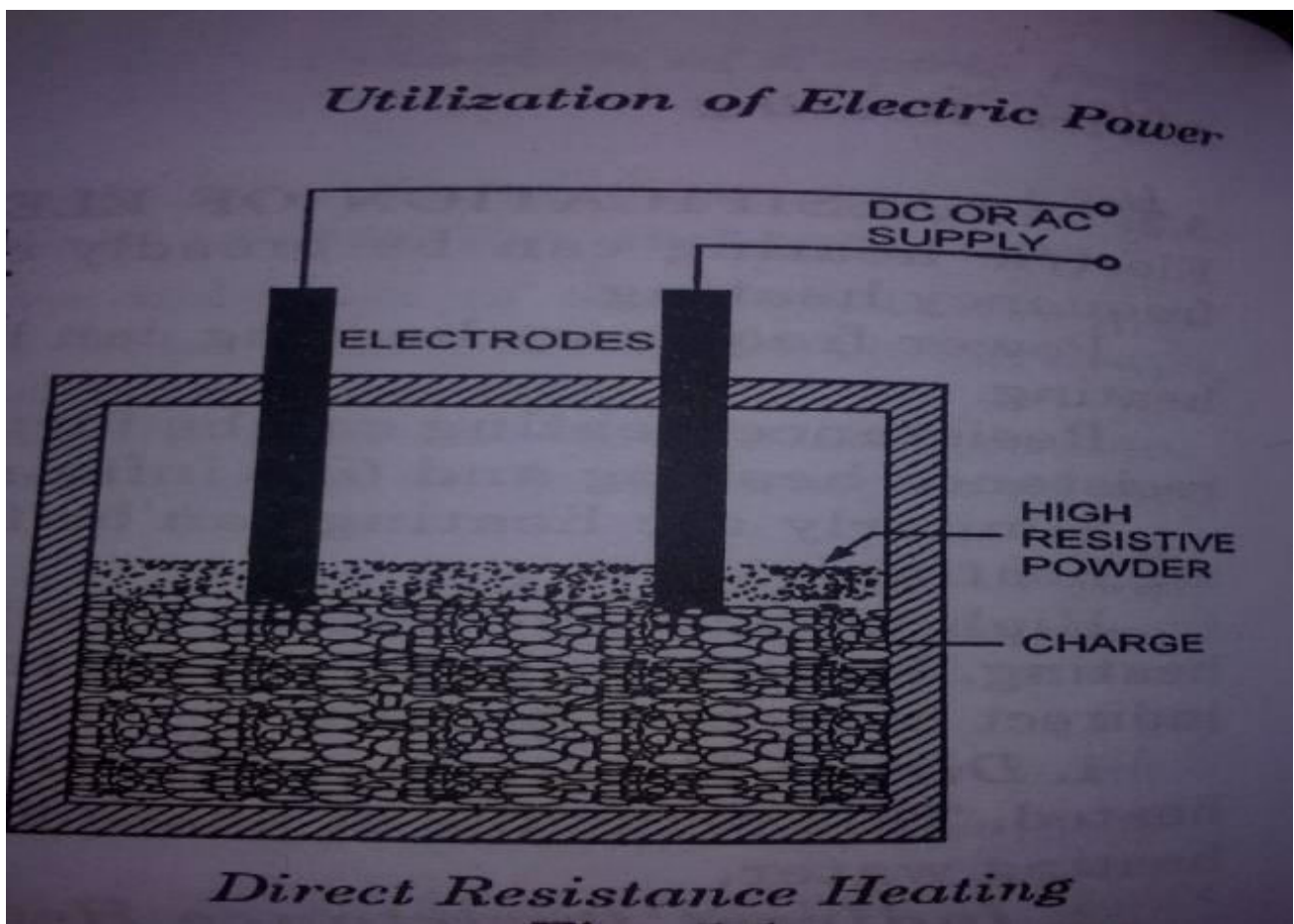

Applications of direct resistance heating:**(a) salt bath furnace:**

They are mainly used for the purpose of tempering, quenching and hardening of steel tools. The advantages of salt bath heating are rapidly, uniformly and selective localized heating combined with production from oxidation.

This type of furnace consists of a bath of same salt as sodium chloride and two electrodes immersed in it. When the current is passed through the electrodes immersed in salt, heat developed and temperature of salt may vary between 1000°C - 1500°C depending upon type of salt used. In this Bath the material to be heated is dipped and necessary heat treatment is given to it. As d.c. would cause electrolysis of salt, therefore alternating current is used. In this method, it must be ensured that the current flows through the salt and not through the job is used.

Since the voltage required is of order of 20V, therefore a tap changing transformer is used.

(b) Electrode boiler:

It essentially consists of electrodes and water placed in a tank. When the supply is given to the electrodes the current passes through the electrodes and water and produces heat. Heat is produced due to the resistance offered by water. The tank in which the water is placed is earthed solidly and connected to earth.

D.c supply is not preferable as it results in electrolysis of water which in turn results in evolution of H_2 at negative electrode and oxygen at positive electrode. But passage of a.c. hardly results in evolution of gas, but heats the water. Thus a.c. is recommended.

Indirect Resistance heating:

In this method, the current is passed through high resistive element known as heating element which is placed either above or below the substance to be heated. The heat produced by the heating element due to I^2R loss is delivered to the material to be heated by one or modes of transfer of heat. i.e. conduction or convection or radiation.

In case of industrial heating where a large amount of charge is to be heated the heating element is kept in cylindrical surrounded by the jacket containing the charge as shown.

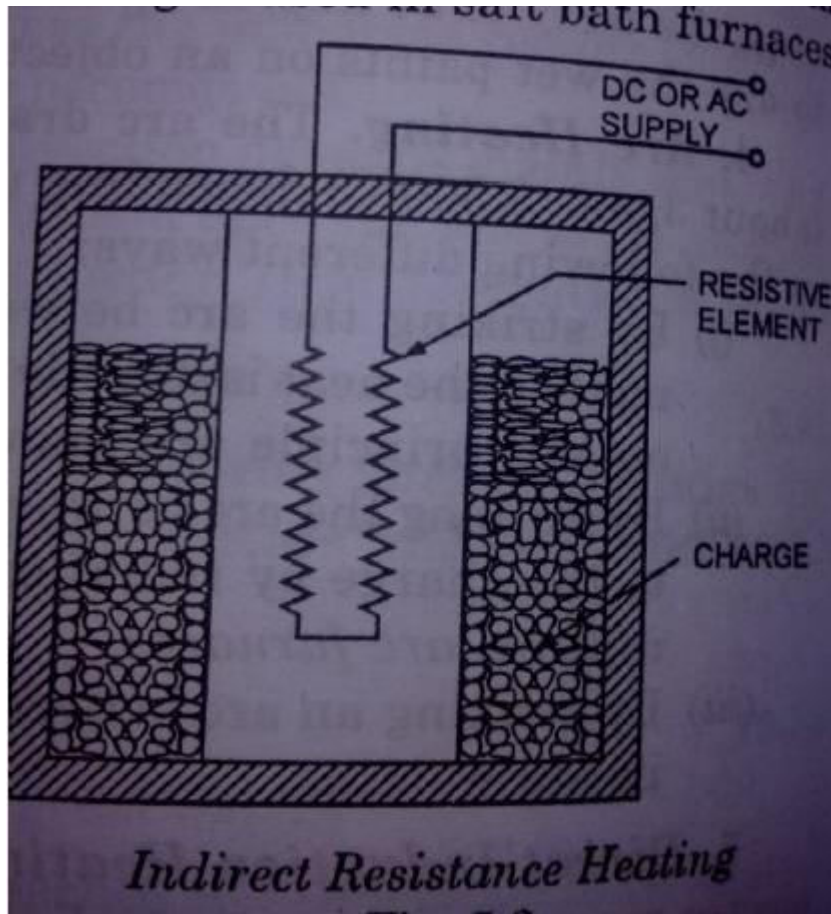

This arrangement provides a uniform temperature control can be provided in this case by presetting the time duration.

This type of heating is used in room heater, immersion heaters, in bimetallic strips and various types of resistance ovens used in domestic and commercial cooking.

Applications of Indirect resistance heating:

(a) Resistance ovens:

It essentially consists of a high resistive material through which an electric current is passed placed in a chamber made of heat insulating material. The element may be in the form of strip or wire and is placed on the top, bottom of the oven depending upon circumstances.

In certain types of ovens, two electrodes project from the opposite walls of the oven and a high current is passed through these electrodes. This type of ovens is used where high temperature is desirable. The shape and size of the oven depend upon nature of the job.

Resistance ovens are used for various purposes such as heat treatment of metals, drying, backing of pottery materials, cooking of food e.t.c.

The temperature of oven (I^2Rt) can be controlled by controlling (i) voltage or current (ii) time and (iii) resistance

Voltage can be varied by using tapped transformer for supply to the oven or by using series resistance so that some voltage dropped across this series resistor.

The automatic control of temperature can be obtained by providing thermostat which will operate a switch to OFF or ON the circuit as soon as the temperature exceeds or fall below the adjusted value.

In order to control the temperature by means of resistance various series and parallel combinations are used for single phase supply and different star-delta arrangements for three-phase supply.

(b) Immersion water heater:

Most of electric water heating is done by immersion heaters which consists of resistance coils placed in slotted cylinders of ceramic material. The material used for resistance coils is nichrome wire coated with magnesium oxide for preventing oxidation of the element which heats up the water due to I^2R loss in it.

Radiant Heating or Infrared Heating:

In this method of heating, heating elements consist of tungsten filament lamps together with reflectors to direct the whole of heat emitted on to charge (material to be heated). The lamps are operated at 2300°C there by giving a large amount of infrared radiations and the reflectors are plated with rhodium which prevents the leakage of heat through the chamber. The lamps used are rated between 250-11,000 watts at 250V.

Radiant heating possess the following advantages:

1. Rapid heating
2. Compactness of heating units.
3. Flexibility.

And this method of heating finds wide applications in

1. Drying paints of radio cabinets and wood furniture
2. pre-heating of plastics prior to moulding.

3. Softening of thermoplastic sheets.
4. Drying of pottery, paper, textiles, e.t.c.

For obtaining best results, the infrared lamps are located at a distance of 25-30 cm from the object to be heated.

High frequency Heating:

Induction Heating:

Induction heating is based on the principle of a.c. transformers. There is a primary winding through which an a.c. current is passed which is magnetically coupled to the charge to be heated. When an a.c. current is passed through primary heating coil, an electric current is induced in the charge and the value of the induced current is dependent on

1. The magnitude of primary current.
2. The ratio of number of turns in the primary and secondary circuit.
3. Co-efficient of magnetic coupling.

The heat develops depend upon the power drawn by the charge and since $P = \frac{V^2}{R}$ therefore

to develop heat sufficient to melt the charge the resistance should be low which is possible only with metals and the voltage must be higher which is obtaining by employing higher flux since the higher the flux linked, the higher is the voltage induced. Thus magnetic materials are found to be suitable for this type of heating because of their higher permeability.

The following diagram shows the electrical representation of heating in which the magnitude of current induced is equal to $3I_p$

In case of charge to be heated is non-magnetic, the heat generated is due to eddy current losses whereas if it is a magnetic material there will be a hysteresis losses in addition. Eddy current loss is proportional to frequency and hysteresis loss is proportional to square of frequency and these laws holds good upto a limited temperature (curie point) since the magnetic materials lose their magnetic properties above curie temperature.

The high frequency require for induction heating is obtained from motor generator set, spark gap converter and vacuum tube oscillator.

The various factors on which the induction heating depends are

1. Magnitude of primary current I_p since if the primary current is high the flux is high and

hence I_s is high and thus heat developed is high.

2. Frequency since hysteresis and eddy current loss depends on frequency.
3. Reciprocal of distance between primary coil and charge because if the distance is less the magnetic coupling is more and thus heat developed is more.
4. permeability of the charge(metal) and resistivity of the charge.

Magnetic materials generally have high permeability and resistivity than non-magnetic materials and thus the induction heating is more adaptable and economical for treating magnetic materials.

Characteristics of Induction Heating:

1. Current flows only on the outer surface of the metal and in doing so heats up the outer surface because if an alternating current is passed through a surface it tends to crowd at the outer surface(skin effect) because of large inductance at the centre.
2. the current flow is restricted axially to that surface of the metal which is directly in plane with the primary coil and thus heat produced is restricted to that portion.
3. As the heat is developed directly inside the metal which is to be heated, the the transfer of heat is very quick.
4. There is no mechanical or chemical contact between the source of energy and the metal to be heated up. Thus no care is to be paid towards the connection.
5. The temperature attained by this type of heating is extremely high since there is no medium as heat is produced in the metal itself.

Induction furnaces:

There are basically two types of induction furnaces:

1. Core type or low frequency induction furnace.
2. Core less or high frequency induction furnace.

I. Core type or low frequency induction furnace:

The furnace consists of a circular hearth in the form of trough which contains the charge to be melted in the form of annular ring. This metal ring is large in diameter is magnetically inter linked with an electrical winding energized by an a.c. source. The furnace is therefore essentially a transformer in which the charge to be heated forms a single turn short circuited secondary and is magnetically coupled to primary by an iron core. The charge is melted due to the heavy current induced in it. When there is no molten metal,

no current will flow in the secondary. Thus to start the furnace, the molten metal is to be poured in the hearth.

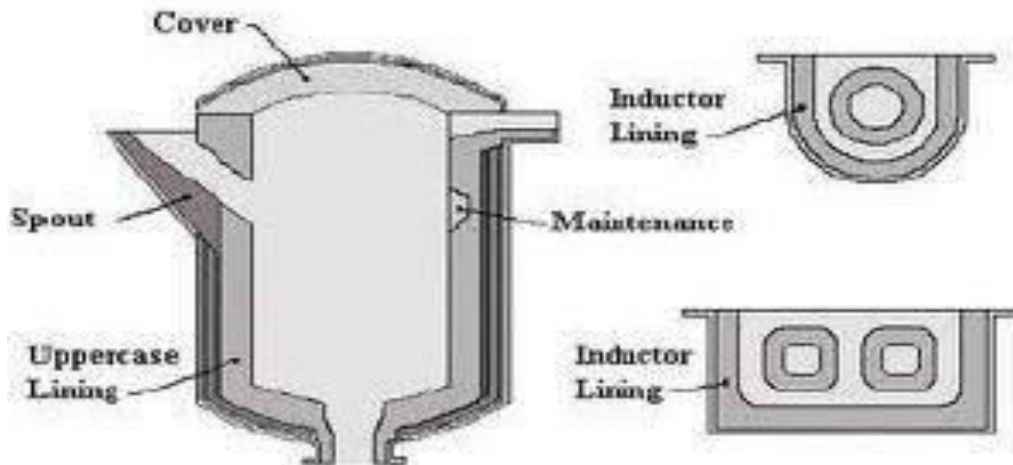

Drawbacks of core type furnace:

1. As the magnetic coupling is between the primary and secondary is poor, since leakage reactance is high and p.f. is low. To overcome this difficulty the furnace must be designed for a low frequency as low as 10Hz which can be achieved by using a frequency changer which involves extra cost.

2. If normal supply frequency is employed for operation of such furnaces the electromagnetic lines of force causes turbulence of molten metal and may become severe unless the frequency is kept low.

3. If the current density exceeds 5 A/m^2 , the pinch effect (formation of bubble) due to electromagnetic forces may cause complete interruption of secondary circuit.

4. The crucible (trough) for the charge is of odd shape and is inconvenient from metallurgical point of view.

5. For functioning of the furnace the closing of secondary circuit is essential which necessitates the formation of complete ring of charger around the core.

On account of the above drawbacks, such furnaces have become absolute now-a-days.

II. Vertical Core Type Induction Furnace:

An improvement in the core type of furnace which overcomes some of the above difficulties employs a vertical channel instead of horizontal channel for charge. The modern form of such a furnace known as Ajax Wyatt furnace. Thus the crucible used for core type furnace.

As the furnace is having a narrow V shape at bottom, therefore tendency of molten metal will be to accumulate at the bottom and even a small amount of charge will keep secondary completed. Hence the chances of discontinuity of circuit are less. The molten metals circulated in V portion by electromagnetic forces between two halves. The inside of the furnace is lined depending upon the charge. The top of the furnace is covered with an insulated cover which can be removed for charging. Necessary hydraulic arrangements are usually made for tilting the furnace to take out the molten metal.

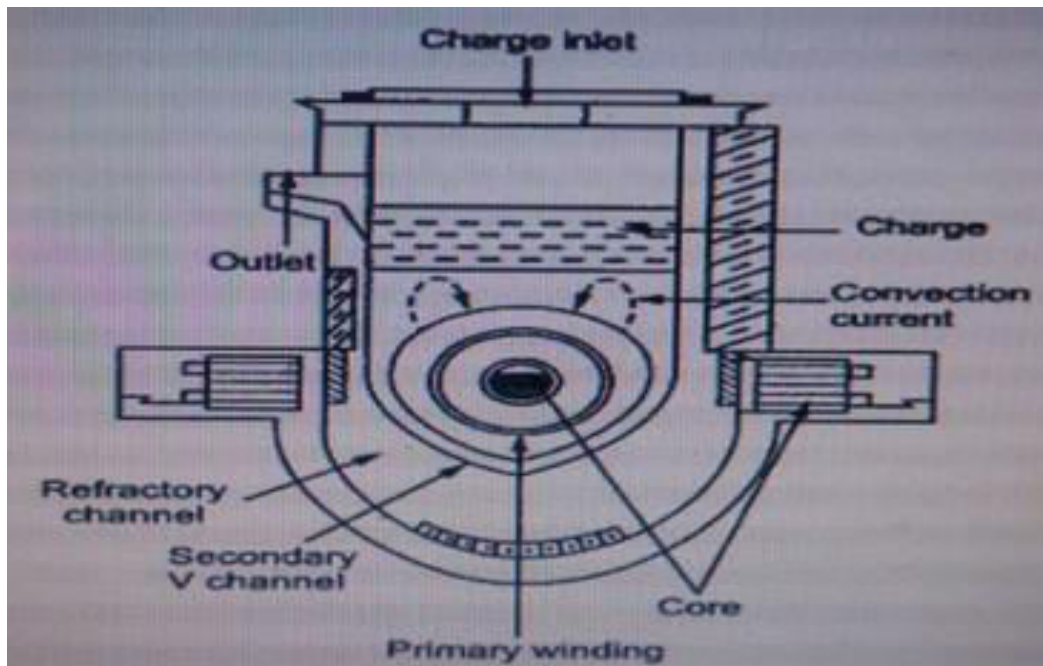

Advantages:

1. High efficient heat, low operating costs and improved production.
2. Absence of crucibles.
3. Consistent performance and simple control.
4. Accurate temperature control, uniform castings, reduced metal losses and reduction of rejects.

5. Ideal working conditions in a cool atmosphere with no dirt, noise or fuel.
6. Comparatively high p.f. since primary and secondary are both on same centre core.

III. Indirect Core Type Induction Furnace:

In such a furnace, an inductively heated element is made to transfer its heat to the charge by radiation. In this type of furnace, the principle of induction has been utilized for providing heat treatment of metal.

It consists of an iron linking with primary winding and secondary also. In this case secondary consists of a metal container forming the walls of furnace. Primary winding is connected to the supply, including current and heating the metal container there by situated in the oven chamber and consisting of a special alloy which loss its magnetic properties at a particular temperature and regains them when cooled to the same temperature. As soon as the oven attains the critical temperature, the reluctance of the magnetic circuit increases many times and the inductive effect corresponding decreases thereby cutting off the heat supply.

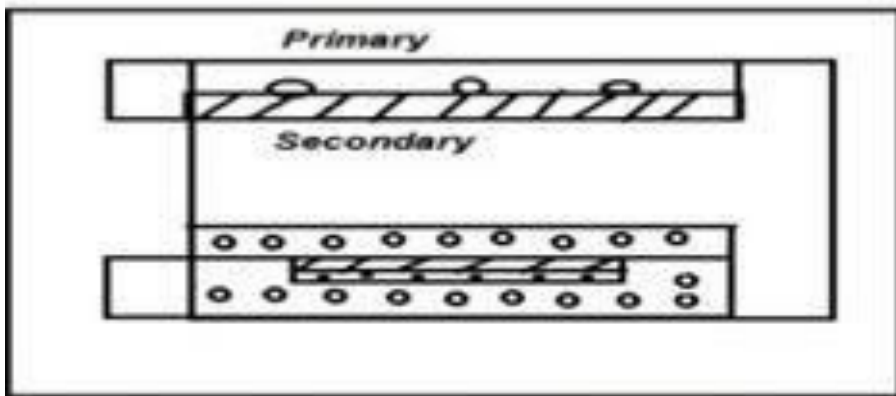

IV. Core Less Induction Furnace:

The eddy currents developed in the magnetic circuit is given as

$$\text{Eddy currents} \propto B^2 \times F^2$$

Where B- flux density, f- frequency

In a coreless furnace there is no core and thus flux density will be low. Hence for compensating the low flux density, the primary current applied to the primary should have sufficiently high frequency. Thus by applying current of high frequency the core of induction furnace can be eliminated there by reducing its weight and increasing the flexibility.

The furnace consists of a ceramic crucible cylindrical in shape enclosed within a coil. Which forms the primary of the transformer and the charge in the crucible, the secondary of the transformer? The charge is put into the crucible and primary winding coil is connected to high frequency a.c supply. The flux created by primary winding set up eddy currents in the charge which flow concentrically with those in the primary winding. These eddy currents heat up the charge to its melting point and set up electromagnetic forces producing stirring action which is essential for obtaining uniform quality of metal.

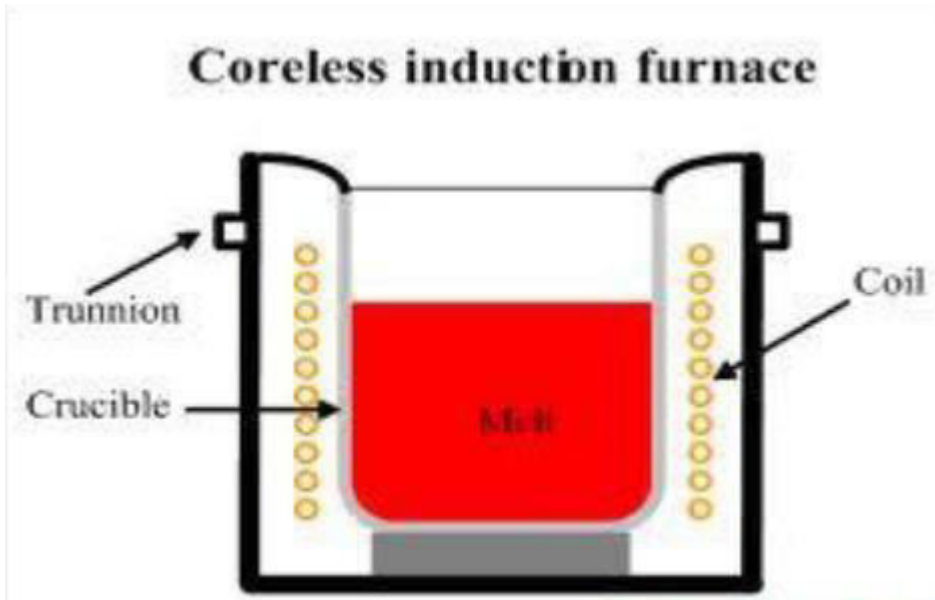

Because of high frequency employed, which is necessary to induce the required voltage in the secondary, the skin effect in the primary coil increases the effective resistance of the coil and hence copper losses tend to high and artificial cooling is necessary. Thus the primary winding coils are since made of hallow copper conductors through which cooling water can be circulated. Insulated supporting structure is employed for such furnaces as the stray magnetic field due to the current in the primary coil may induce eddy currents in the metal supporting structures there by leading to the over heating of strictures and reduction of efficiency.

The choice of frequency of primary current can be ascertained by the following penetration formula in which the secondary current is assumed to be uniformly distributed over a cylindrical layer at the outside edge of the crucible and having a thickness.

Advantages:

1. They are fast in operation.
2. Precise control of power into the charge can be employed and thus uniform quality of product obtained is unattainable by any other method.
3. Absence of dirt, smoke, noise e.t.c.
4. Crucible of any shape can be used.
5. The eddy currents in the charge result in automatic stirring.
6. Erection cost of a coreless furnace is less.
7. Operation cost is also low.
8. It is possible to operate coreless induction furnace intermittently as no time is lost in warming up.

Applications:

1. These furnaces are used for production of steel and are also used for melting of non-ferrous metals like brass, bronze, copper, aluminium, magnesium e.t.c.

2. They are also used for specialized applications such as vacuum melting, duplexing steel, heating of charges of non-conducting materials by use of conducting crucibles.

Applications of induction heating:

1. surface Hardening: The materials used for making parts such as spindle, saw blades, gears, axles should be hard and tough to withstand the wear which possible with induction heating since with induction heating it is possible to concentrate the heating effect to desirable portion.

2. Deep hardening: With the help of induction heating, hardening of material to any depth is possible and hence this type of heating is used for deep hardening of articles such as screw driver, tools, drills e.t.c.

3. Tempering: In some mechanical process, the work pieces becomes more hard than required and may need tempering to loose their hardness for tempering accurate control of heat is required which is possible only with induction heating.

4. Smelting: Induction heating at high frequency is preferred for extraction of metal from ore where the process is to be carried out in some protective atmosphere or vacuum.

5. Soldering: For soldering it is essential that required amount of heat is to developed at the soldering point where as the remaining portion of the solder may remain cold which can be achieved economically and efficiently by induction heating. With the help of induction it is possible to melt various metals in suitable furnaces.

High Frequency Eddy Current Heating:

In this method of heating, the machine part to be heated is surrounded by a coil through which an alternating current at high frequency is passed. The high frequency current carry coil known as the heater coil or work coil and the material to be heated is knoen as charge load. The electromagnetic field developed in the coil produces heating due to eddy current set up in the part to be heated.

Since the eddy current loss is proportional to the product of square of supply frequency and flux density.

Therefore by controlling frequency and flux density, the amount of heat can be controlled.

Induced eddy current is of greatest magnitude at the surface of material to be heated and its value decreases as we go inside the material due to the skin effect.

Since the depth of penetration of eddy currents into the charge is inversely proportional to supply frequency as given by

Therefore eddy current heating can be restricted to any depth of the material by judicious selection of frequency of heating current. This frequency employed is in range of 10,000-400,000 Hz.

In case of magnetic material, in addition to eddy current loss, hysteresis loss also contribute of production of heat.

Advantages:

1. It is quick, clean and convenient method.
2. Amount of heat wasted is less since heat is produced in the body to be heated up.
3. Control of temperature is easy.
4. The can be made to penetrate into metal surface to any desired depth.
5. Unskilled labour can also operate the equipment.
6. The amount of heat produced can be accurately controlled by suitable timing devices.
7. With this type of heating, it is possible to heat many different objects of different shapes and sizes with the same coil.

Disadvantages:

1. Generation of heat is costly.
2. Efficiency of equipment is quite low.
3. Initial cost of equipment is quite high.

Applications:

1. The high frequency eddy current heating is used for surface hardening in which the desired depth of penetration of heat can be obtained by judicious selection of frequency which reduces the cost, labour and time considerably.
2. This method is employed in annealing of metals which saves a lot of time along with the prevention of scales on metals obtained by conventional methods.
3. Eddy current heating can be economically employed for soldering precisely for high temperatures.
4. This method of heating is also used for welding, drying of paints, melting of precious metals, sterilization of surgical instruments and forging of bolt heads and rivet heads.

Dielectric Heating:

When non-metallic materials i.e. insulators such as wood, plastic, china glass, ceramics etc. are subjected to high alternating voltage their temperature will increase after some time. This increase in temperature is due to the conversion of dielectric loss to heat. The material to be heated is placed as slab between the metallic plates or electrodes connected to high frequency a.c. supply.

Dielectric loss is dependent upon the frequency and high voltage therefore for obtaining adequate heating effect high voltage at about 20 Kv and frequency of about 10-30 MHz are usually employed. High frequency is obtained from valve oscillator.

The current drawn by the capacitor when connected to an a.c. supply voltage does not lead the supply voltage by exactly 90° since it is not possible to get a pure capacitor and there is always some resistance due to which heat is always produced in the dielectric material placed in between the two plates of capacitor. The electric energy dissipated in the form of heat energy in dielectric material is known as dielectric loss.

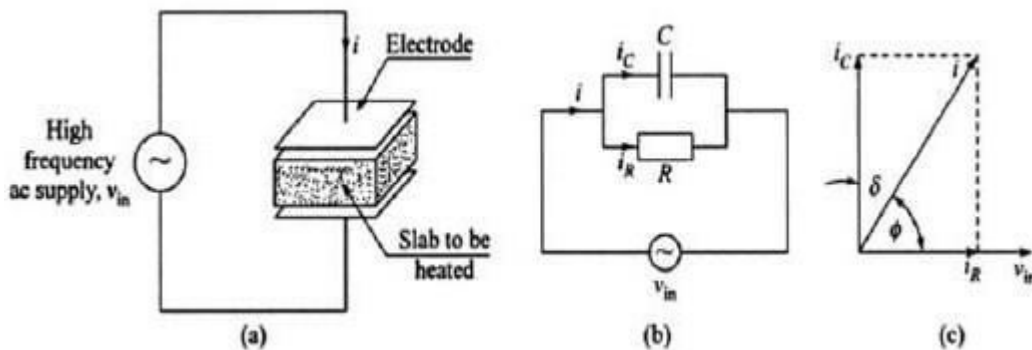

Advantages:

1. If the material to be heated is homogeneous and alternating electric field is uniform, heat is developed uniformly and simultaneously throughout the entire mass of charge.
2. As material to be heated is non-conducting, therefore with the help of other methods of heating is not possible to heat the material.

Applications:

The cost of the equipment required for dielectric heating is so high than it is employed where other methods are impracticable and too slow. Some of the applications of this type of heating are:

(i) synthetics: The raw materials called plastic performs used for synthetics are required to be heated uniformly before putting them in hot moulds so that the whole mass becomes fluid at a time, otherwise if the raw material is put directly in the moulds usually heated by steam the outer surface of the perform will become hot and starts curing while inner surface does not reach the fluid temperature there by resulting in unequal hardening of plastic.

(ii) Diathermy: Dielectric heating is employed for heating tissues, and bones of body required for the treatment of certain types of pains and diseases.

(iii) Sterilization: Dielectric heating is quite suitable for sterilization of bandages, absorbent cotton, instruments e.t.c.

(iv) Baking of foundary cores: Dielectric heating is more suitable foe baking foundary cores where thermo setting binders are employed as they set instantaneously when brought to polymerizing temperature.

(v) Textile industry: In textile industry, dielectric heating is employed for drying purpose.

(vi) **Food processing:** The dielectric heating for food processing is one of the most modern method and set fourth such processes which are outside.

The dielectric heating is used for;

- (a) Heating of general processing such as coffee roasting, chocolate industry.
- (b) Cooking of sea foods such as oysters without removing the outer shell.
- (c) Dehydration of fruits, milk, cream and eggs.
- (d) Defrosting of frozen foods such as meat and vegetables.

(e) For control of bacterial growth and production of germicidal reactions, the food product are heated and to prevent the product losing the flavor, they are dielectric heated.

Advantages of High frequency heating(Dielectric, Induction, Eddy current):

High frequency equipments are very costly but are preferred due to the fallowing advantages:

1. The quantity of heat can be accurately controlled with the help of electric clocks which are function of frequencies as they are run by synchronous motors.
2. The working atmosphere is free from flue gases, smoke and dirt.
3. The equipment used is compact and hence the space required is less.
4. It is easy to maintain high frequency equipment.
5. Operation of high frequency equipments is easy and does not required skilled labour.
6. As the heat is developed in the material to be heated, loss of heat is less.
7. High frequency equipment can be made automatic.
8. Non-conducting materials can be economically heated by high frequency heating (Dielectric) which is not possible with other methods.
9. Heat provided by high frequency methods is uniformly and evenly distributed.
10. The quality of product obtained by these methods is improved.

ELECTRIC WELDING

Introduction: The word welding means the joining of two metals places together by heating them to melting point.

The most essential requirements for welding is heat which can be obtained either electrically by means of a gas torch. Pressure may also be employed but this is not essential in many processes. The result of welding is homogeneous material of the composition and characteristics of two parts which are being joined together.

Advantages of Welding:

1. A good weld is as strong as base metal.
2. General equipment is not very costly.
3. Welding permits considerable freedom in design.
4. A large number of metals/alloys both similar and dissimilar can be joined by welding.
5. Welding can be mechanized.
6. Portable welding equipments are available.

Disadvantages of Welding:

1. Welding gives out harmful radiations (light) and fumes.
2. A skilled welding is must to produce a good weld.
3. Edge preparation of work pieces is generally required before welding them.
4. Jigs and fixtures are generally required to hold and position the parts to be welded.
5. If welding is not done carefully it may result in the distortion of work piece.

Electric Welding:

Electric welding is a process by means of which two metal pieces are joined together by the heat produced due to the floe of fault current.

Due to the reliability of welded joints in comparison to riveted or bolted joints, electric welding has been adopted in many engineering fields. There are two methods by which electric welding can be carried out. These are

1. Resistance Welding.
2. Arc Welding.

Resistance Welding:**Definition:**

Resistance welding is the process in which a sufficiently strong electric current is sent through the two metals in contact to be welded which melts the metal by the resistance they offer to the flow of electric current.

In resistance welding a heavy current (above 100A) at a low voltage is passed through the work piece and the heat developed by the resistance to the flow of current is utilized.

The heat developed at the contact area between the pieces to be welded reduces the metal to a plastic state, the pieces are then pressed together to complete the weld. In the process, two electrodes of low resistance are used and metals to be welded are pressed between the electrodes. The electric voltage required ranges from 4- 12V depending upon the composition, area, thickness e.t.c. of metal pieces to be welded. Alternating current is found to be most suitable for resistance welding as it can provide any desired combination of current and voltage by means of a transformer.

The heat developed is given by I^2Rt

Where I- current flow (A)

R- resistance (ohms)

t- time for which the current flows

The resistance in the above equation is made of:

1. Resistance of current path in the work.
2. Resistance between the contact surfaces of parts being welded.
3. Resistance between the electrodes and surface of parts being welded.

In order to develop higher temperature between the interfaces of the work to be welded rather than at surface of work in contact with the electrode, it is necessary to keep the resistance between the electrodes and surface of the body being welded to a minimum.

In resistance welding, the magnitude of current is controlled by varying primary voltage of a transformer. The time for which current flows is very important. Usually automatic arrangements are devised which switch off the supply after a predetermined time.

Advantages:

1. Fast rate of production.

2. Less skilled workers can do the job.
3. Both similar and dissimilar metals can be welded.
4. High reliability and reproducibility are obtained.
5. Employs semi automatic equipments and maintenance cost is less.
6. No rod is required for welding.

Disadvantages:

1. Initial cost of equipment is high.
2. Skilled persons are needed for the maintenance of equipment and controls.
3. In some materials, special surface preparation is required.
4. Bigger job thickness can not be welded as it requires large amount of current.

Applications:***Resistance welding is used for:***

1. Joining sheets, bars, rods and tubes.
2. Making tubes and metal furniture.
3. Making cutting tools.
4. Welding aircraft and automobile parts.
5. Making fuel tanks of cars, tractors e.t.c.
6. Making wire frabic, grids, grils, containers e.t.c.

Types of Resistance Welds:

Depending upon the shape of the weld and the manner in which the weld is obtained, the resistance welding can be classified as:

- (a) Spot Welding.
- (b) Projection Welding.
- (c) Seam Welding.

(d) Butt Welding.

(a) Spot Welding:

Definition:

Spot welding is a form of resistance welding in which the parts or pieces are joined in spots by heating relatively small sections of parts or pieces between suitable electrodes under pressure.

It is a method in which two electrodes are placed on both sides of the work. With the help of transformer the arrangements is such that current is passed from the electrode on one side directly through the work into the electrode on the other side and back to the transformer.

The current required for this type of weld is 5000A and voltage between electrodes is less than 2V. The time period of flow of current depends upon the thickness and kinds of materials. For obtaining good welds, having strength the work is cleared thoroughly.

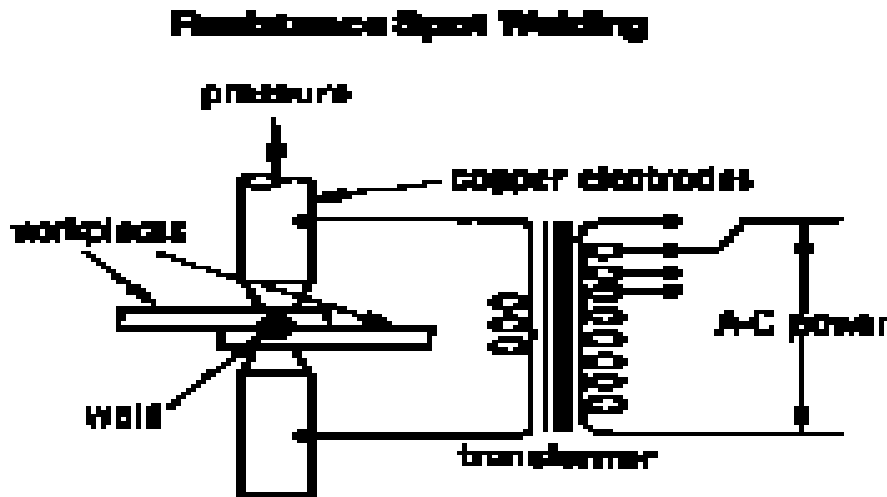

This type of welding is usually used for joining or fabricating sheet metal structures. It is also used in cases where the number of welds required is relatively small. The lower cost of the equipment makes spot welding economical for small quantities.

(b) Projection Welding:

It is a modified form of spot welding. In this type of welding, electrodes used are flat metal known as plates known as platens. The two pieces of base metal are held together between the platens out of which one piece have projections or bumps which are obtained by passing through a machine when

current is passed from a transformer to the pieces to be welded, metal gets heated up near the projection area and changes to plastic state.

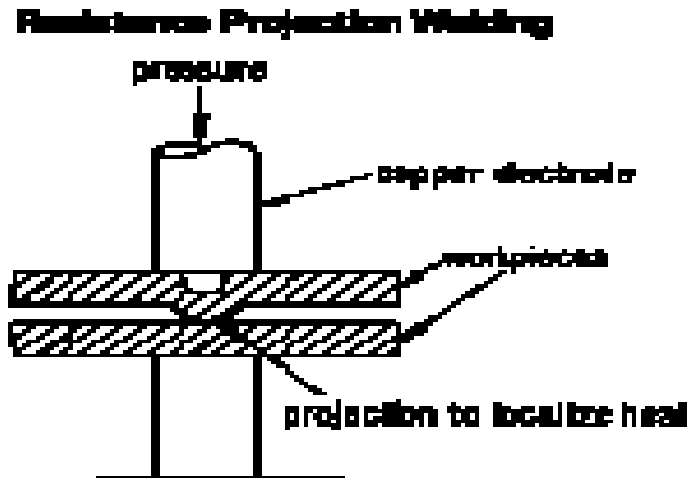

The heated and softened projection collapses under the pressure of the electrodes thereby forming the weld.

This type of welding is used where small nuts are to be welded to large components or the welding of the refrigerator condensers, crossed wire welding e.t.c.

Advantages:

1. Projection made the welding process simple.
2. With the projection welding, it is easy to weld certain parts where spot welding is not possible.
3. It is possible to join several welding points in projection welding.

(c) Seam Welding:

Seam welding can be defined as a series of spot welds made progressively along a joint between the two overlapping pieces of sheet metal.

In this method, the work pieces to be welded are cleaned, overlapped suitably and are placed between two circular electrodes which clamp the work pieces together by electrode force. A current impulse is applied to the circular rollers to the material in contact with them. The heat generated makes the material plastic and pressure from the electrodes completes the weld. Due to the current impulse applied the power driven circular rollers are set in rotation and the work piece moves steadily forward.

Throughout the welding period, the electrodes revolve and the work passes through them with a specific speed.

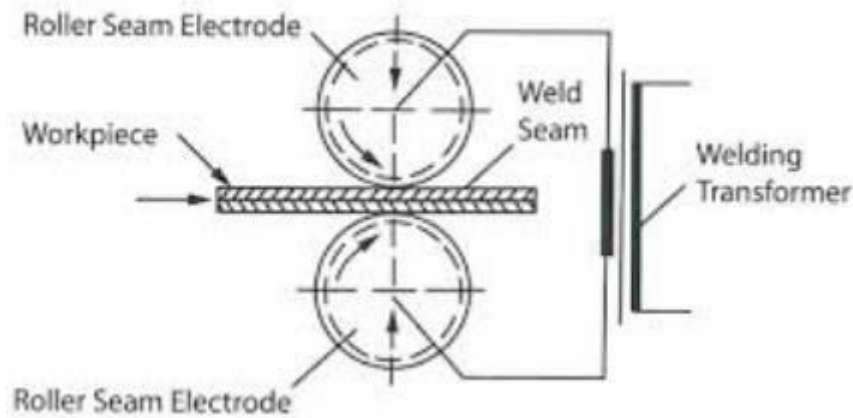

The numbers of spots obtained per meter are between 200 to 400 depending upon the nature of the joint required. This type of welding provides pressure tight or leak proof joint. Seam welding is employed for welding pipes, conduits, tanks, transformers, refrigerators, aircrafts and various types of containers.

(d) Butt welding:

It is of two types namely,

- (i) Upset butt welding.
- (ii) Flash butt welding.

(i) Upset butt welding:

In this method, the two pieces to be welded are gripped firmly one in each clamp and are correctly aligned so that when brought into contact one with other by sliding the movable clamp to the fixed one they fit together. Force is applied so that faces of two pieces touch together and remain under pressure.

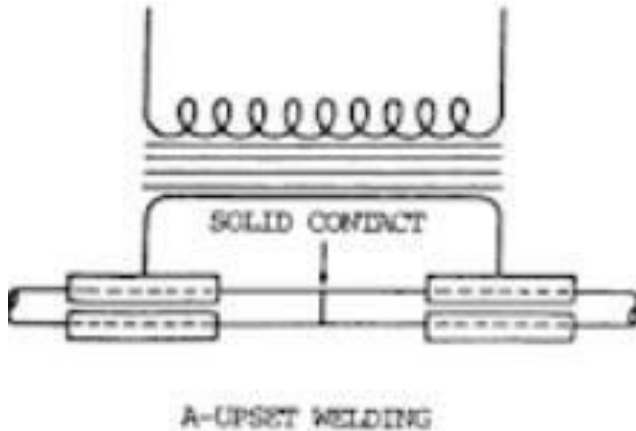

When a heavy current is passed from one piece to another, the resistance to the electric current flow heats the faces to fusion temperature and they become plastic which when pressed together more firmly there by forming a debse joint.

The voltage required is 2 - 8Volts and currents varies from 50A to several hundred amperes depending upon the material and the area to be welded at a time.

This type of welding is used principally on non-ferrous metals for welding bars, rods, wires, tubing e.t.c.

(ii) Flash butt welding:

In this process of welding no special preparation of faces to be welded is necessary. In flash burr welding the voltage to the metal parts to be **welded is applied** before putting them together. Protruding small parts of the faces to be welded are brought into contact, the heat developed owing to high resistance of the contact areas raises the temperature of the material at these points and causes them to melt. The molten metal is blown out arc a small arc is formed which burns away some portion of the material and temperature goes on increasing until the final welding temperature is reached.

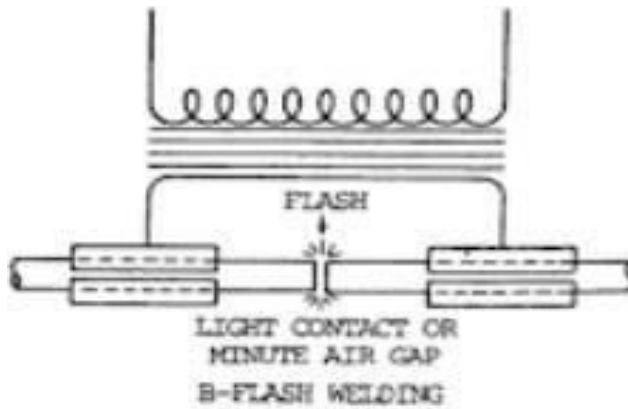

As this stage, the pressure of the electrodes is greatly increased to forge the parts together and expel the molten metal there by making a solid weld. The metal expelled forms a flash round the joint which is removed later on cutting or grinding.

Advantages:

The advantages of flash butt welding over upset welding;

1. Power requirement is less.
2. No special attention is to be paid to the surfaces being joined.
3. All the foreign materials appearing on the joining surface will be burnt due to the flash, thus the weld obtained is pure and clean.

Flash welding finds applications in automotive and aircraft products, household appliances, refrigerators etc.

Comparison of upset and flash butt welding:

Upset welding	Flash butt welding
1. No arcing (and hence flashing) takes place between the surfaces to be joined.	1. Arcing takes place between the surfaces to be joined.
2. It consumes more current.	2. It consumes less current.
3. The time for weld is less.	3. The time for weld is more.
4. Constant pressure is applied during heating which eliminates flashing.	4. Heat application precedes pressure.

Electric Arc Welding:

Electric arc welding is the process in which the pieces to be welded are brought to the proper welding temperature at point of contact by the heat liberated at the arc terminals and in the arc stream so that metal arcs completely fused in to each other, forming a single solid homogenous mass after it solidifies.

In this process an electric arc is produced by bringing conductors connected to a distance. The current continuous to flow across the small gap and gives intense heat. The heat developed is utilized to melt the part of work piece and filler metal and thus form joint. So,arc welded joint is a union of metal parts made by localized heating without any pressure. That is why this type of welding is known as non-pressure welding.

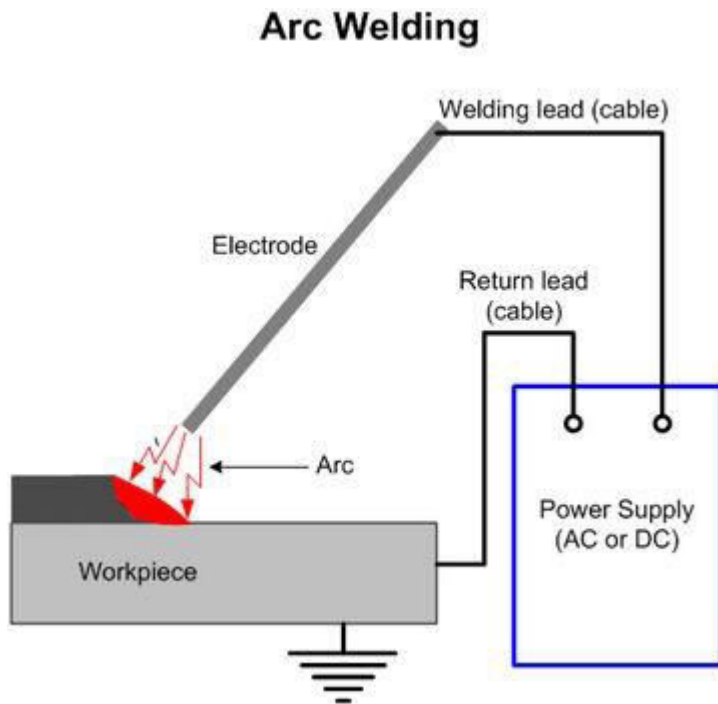

The temperature in order of 3600°C at which mechanical pressure is not required for jointing. A.C. and d.C both can be used in arc welding. The arc voltage varies between 70V to 100V on a.c. whereas it is 50 to 60V on D.c.

Electric arc welding is widely used for joining of metal parts, the repair of fractured casting and fillings by the deposition of new metal on worn out parts.

The different methods of arc welding are:

1. Carbon arc welding.
2. Metal arc welding.
3. Hydrogen arc welding.
4. Inert gas metal arc welding.

Carbon Arc Welding:

It is process in which welding is brought about by heating the work piece with an electric arc struck between a carbon electrode and the work piece.

In this process, a carbon or graphite rod is used as negative electrode and work being welded as a positive. Mostly graphite electrodes are used as they use yield longer life and have low resistance and thus capable of conducting more current. The arc produced between the two electrodes heats the metal to melting temperature which about 3200°c on positive electrode.

The use of carbon rod as negative electrode is that less heat will be generated at the electrode tip than the work and carbon will not fuse and mix up the job. For this type of welding d.c. is preferred since no fixed polarity can be maintained in case of a.c.

In this method arc is maintained between the job and carbon electrode held in a holder and ground. The arc is struck by touching the electrode with the job momentarily and then taking away the electrode at a definite distance apart. The arc is allowed to impinge on the surface to be welded till a molten pool forms and then the holder is steadily moved along the joint. Filler metal and flux may or may not be used depending upon the type of joint and material to be welded.

Carbon Arc Welding (CAW)

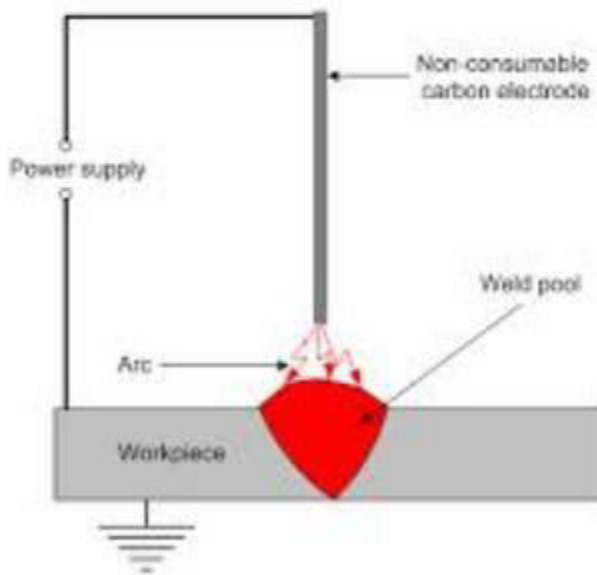
**Advantages:**

1. Heat input to the work piece can be easily controlled by changing the arc length.

2. Process is suitable for welding of thinner pieces.
3. Total welding cost is less as compared to other welding processes.
4. Process is simple and good welding skill can be acquired in short time.

Disadvantages:

1. There are chances of carbon being transferred from electrode to weld thus causing a harder weld deposit in case of ferrous materials.
2. In the absence of proper electrode geometry, arc blow results which give poor welds with blow holes.
3. A separate filler metal is needed which when used slows down the welding speed.

Applications:

1. For welding steel, aluminum, nickel, copper and a good number of other alloys.
2. Carbon arc can also be employed for brazing, preheating and post heating of welded joints.

Metal Arc Welding:

It is an arc welding process where in the welding is brought about by heating the work piece with an electric arc setup between a flux coated electrode and the work piece.

In this type of welding a metal rod of same metal as being welded forms one of electrode and also serves as a filler rod and no filler rod is used separately. Heat required for welding is obtained from the arc struck between a coated electrode and the work piece. The arc melts the electrode end and the job. Material droplets are transferred from the electrode to the job through the arc and arc deposited along the joint to be weld. The electrodes are coated with a covering to prevent the contamination of molten weld metal since the flux coating generates a gas shield round the arc which protects the weld against the foreign matter. Fluxing not only protects the weld but also stabilizes the arc and governs the rate and amount of metal in weld.

For metal arc welding both A.c and D.C can be used. However a.c. is preferable as compared to D.c since d.c metal arc welding may result in arc blows.

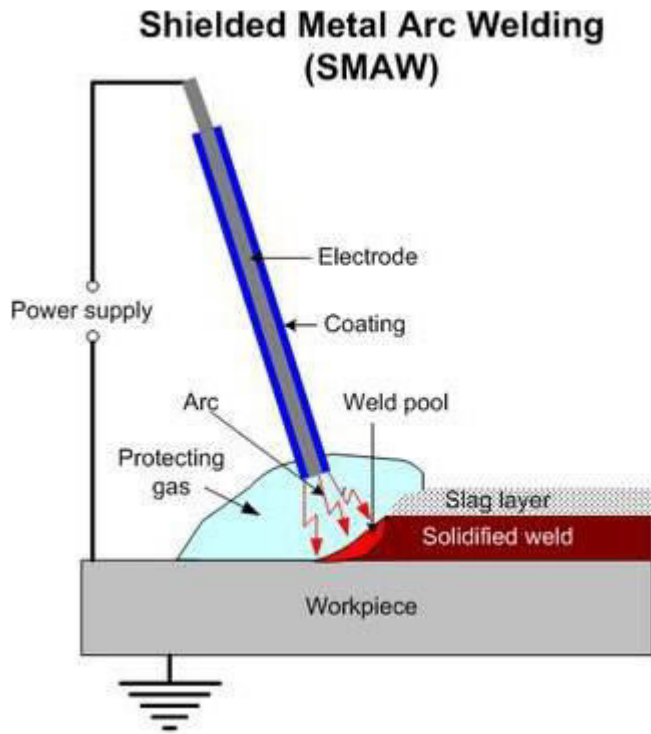

Arc Blow:

Arc blow represents the distortion of arc stream from intended path by the existence of non-uniform magnetic field.

Arc blow results in welding difficulty and increase in consumption of energy. With a.c, arc blow is sufficiently low.

Advantages:

1. The equipments used for this weld are portable and cost is fairly low.
2. It finds innumerable applications because of the availability of a wide variety of electrodes.
3. Welding can be carried out in any position.
4. Joints which because of their position are difficult to be welded by automatic welding are easily accomplished by metal arc welding.

Disadvantages:

1. Because of the limited length of each electrode, and brittle flux coating on it, mechanization is difficult.
2. In case of long welding joints, as one electrode finishes the weld is to be progressed with next electrode which may result in defect while replacing.

3. The welding process is little bit difficult because of fumes and particles of slag.

Applications:

1. It is as both as fabrication process and for maintenance and repair jobs.
2. This process finds applications in
 - (a) Air receiver, tank, boiler and pressure vessel fabrications.
 - (b) Ship building.
 - (c) Building and bridge construction.
 - (d) Pipes and penstock joining.
 - (e) Automotive and air craft industry.

Hydrogen Arc Welding:

It is a welding process in which the welding is brought about by an arc struck between the two tungsten electrodes while a stream of hydrogen gas is passed through the arc and around the electrodes.

The electrodes used are connected to a.c supply and hydrogen is supplied from steel cylinders which serves two purposes:

1. It acts as protective screen for the arc and thus prevents formation of impurities.
2. It acts as a cooling agent for glowing tungsten electrode points.

The arc developed between electrodes. Molecules of hydrogen on being heated are converted into atomic form and these atoms when come in contact with the cold base metal, a large amount of heat is developed which is used in making fusion welds.

This process is capable of producing smooth, uniform strong and additive welds. Or any metal or alloy, ferrous and non-ferrous can be welded.

Welding of the thin shields, production of tubing and the repairing of expensive tools and dies are some of the common uses of this method.

Inert Gas Welding:

It is a gas shielded metal arc welding process which uses the intense heat of an electric arc between a continuously fed consumable electrode wire and the metal to be welded. A consumable bare electrode wire producing the filler metal is fed through a welding torch which also carries a nozzle as shown in the following figure.

Through this nozzle helium or argon gas is blow around the arc and on to the weld. This type of welding is suitable for thin materials because of the low arc voltage. A.c and d.c both can be used.

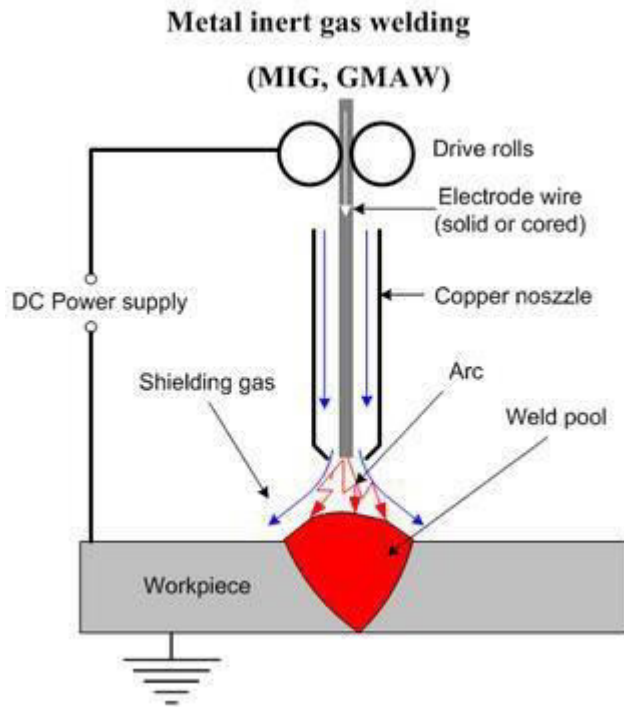

Advantages:

1. As atmosphere is inert, and the electrodes do not come in contact with molten metal, fluxing is not required which prevents the decomposition of foreign materials on the weld.
2. Heat is concentrated to the minimum and thus distortion is less.

This method is usually employed for aluminium, magnesium, their alloys and stain less steel.

Comparison between Resistance and Arc Welding:

Resistance Welding:	Arc Welding
<ol style="list-style-type: none"> 1. It uses only a.c. 2. External pressure is required. 3. Heat is developed due to flow of current through the contact resistance mainly. 4. No material is added in any form to get the two pieces joined. 5. Power factor is very low. 6. Maintenance required is less as the temperature reached is not high. 7. It can not be used for repair work hence it is most suitable for mass production. 	<ol style="list-style-type: none"> 1. It uses both a.c and d. 2. No external pressure is required hence the equipment is more simple and easy to control. 3. Heat is developed due to the arc electrode and the work piece. 4. Suitable filler metal electrodes are necessary to get proper strength. 5. Power factor is poor. 6. Maintenance is more as temperature of the arc is high and so likely to damage the work if not properly handled. 7. Not suitable for mass production and hence not suitable for repair work and where more metal is to be deposited.

Requirements of Good Weld:

1. The weld is said to be good weld if it is free from external defects such as irregular width and deviation of weld from prescribed dimensions.
2. On order to get good weld, it is essential to obtain the absolute fusion of metal and electrode otherwise lack of fusion impairs the strength of weld unreliable.
3. A good weld must be from pores(gas pores) which makes weld leaky and weak.
4. Good weld should be free from cracks which may come by non uniform heating and cooling.

Electric Welding Equipments:

Equipment required for welding are:

1. Welding power source.
2. Welding cables.
3. Electrode holder.
4. Welding element and hand shield.
5. Protective clothing including hand gloves.
6. Chipping hammer, wire brush e.t.c.

Welding power Sources[Electric Welding Sets]:***The electric welding sets may be selected depending upon the following factors:***

1. Available power (A.C or D.C single phase) where there is no power a diesel driven engine may be used.
2. Available floor space.
3. Initial costs and running costs.
4. Location of operation.
5. Required output.
6. Duty cycle.
7. Type of work.

The power sources may be either D.c. or A.C type.

D.C welding Sets:

DC welding sets are of two types:

- (i) Generator sets.
- (ii) Refrigerator sets

(i)Generator sets:

A dc generator produces direct current in either or reversed polarity and it is powered either by an electric motor or a diesel engine. Diesel operated generator sets are suitable for outdoor applications

where power is not available. The current supplied by dc generator is obtained by use of a commutator, a generator is designed such that it will compensate for any change in voltage thus ensuring a stabilized arc.

Since most of welding processes requires low voltages with high value of current therefore differential compound dc generator in an ideal selection since it has dropped volt-ampere characteristic. The control may be obtained by tapping series field or a suitable shunt across series field winding.

Advantages of Dc generator sets:

1. Straight and reversed polarity can be employed.
2. Welding can be carried out in any position.
3. Nearly all ferrous and non-ferrous metals can be welded.
4. D.C is most universal in application. it can be used in practically all applications.
5. Generator output is not affected by normal variations in power line voltage.

Disadvantages of Dc generator sets:

1. High initial cost.
2. Higher maintenance cost.
3. Noisy machine operation.

(ii) Rectifier sets:

These sets essentially consists of a transformer containing an electrical device called rectifier which changes a.c to d.c. the rectifier may consists of metal plate coated with a selenium compound or silicon diodes each unit having the special property of allowing current flow in one direction only. A rectifier is installed with a fan to cool the transformer. A rectifier unit may be designed for a single phase or three phase supply d.c voltage is controlled by regulating the transformer output.

Advantages:

1. They can provide both straight and reversed polarity.
2. They have good performance as it can be precisely controlled.
3. Their current can be adjusted by using a remote control kept near the operator.

Disadvantages:

The life of selenium plates is limited to about seven years only.

A.C Welding Sets:

A.C welding sets are single phase or three phase step down transformer which provide low voltage (80-100v) power for welding with some means of output control. An a.c. transformer takes power directly from the mains and transforms it to voltage/current required for welding. A transformer is a normal frequency machine.

Since a.c. passes through zero twice every cycle, it means that there are two periods in every cycle when the welding current is zero during which arc would extinguish and make continuous welding difficult for arc welding which is prevented by development of electrode coatings that produce a more complete ionization in the arc stream and keep that arc igniting as current passes through zero.

The transformer is housed in a steel tank which has external tubes. The tank is filled with transformer oil to cool the transformer core by convection thereby preventing its overheating when working under heavy load conditions. Instead of being oil cooled, some transformers employ electric fans and are thus air cooled.

The transformer consists of a limited core on which primary and secondary circuits are wire wound tightly around the core. The two circuits are thoroughly insulated from one another.

Advantages:

1. It is least expensive, lightest and small welding machine.
2. There is freedom from magnetic arc blow that often occurs when welding with a d.c. machine.
3. Operating and maintenance costs are low.
4. Since there are no moving parts in transformer, the operation is noise less and there is hardly any wear.
5. Overall electrical efficiency is high.

Disadvantages:

1. Polarity cannot be changed.
2. Because of alternating nature of current flow, starting the arc is more difficult than with d.c.
3. Low power factor.

Applications:

1. Mostly used in industrial welding operations.
2. Popular application of transformer is production welding on heavy gauge steel.
3. Transformers are mostly used for flux shielded metal arc welding.

Welding cables:

Two cables are needed for welding one of which connects the electrode holder or electrode to the welding power source and other connects the job with the welding source. These cables are well insulated with rubber above which a durable layer of rubber is woven and the cables are checked periodically for insulation.

Electrode holder:

Electrode holder is a device used for mechanically holding the electrode and conducting current to it. The electric jaws are made in electrode holder to hold the bare end of the electrode in either a vertical or an angular position and are completely insulated to protect the operator against electric shocks.

Welding helmet and shield:

Helmet is a protective used for shielding and protecting the face and neck of the welder and is also be worn on the head of the operator. Hand shield is also a protective device used for shielding and protecting the face and neck of the welder and is held in the hand of the welder. The use of hand shields and helmet protect the operator eyes from getting damaged due to the UV rays and infrared rays of welding arc.

Protective clothing:

Protective clothing usually includes the apron and gloves.

Apron provides protection to the clothes of welder from hot spattering particles may be made of chrome leather.

Gloves protect the hands of the welder from UV rays and a spattering metal which may be made of leather.

Chipping hammer and Wire brush:

A chipping hammer is chisel shaped and is pointed on the end to aid in the removal of slag from over the weld bead.

A wire brush made up of stiff steel wire embedded in wood removes small particles of slag from the weld after chipping hammer have done its job.

Comparison between A.C and D.C Welding:

D.C Welding	A.C Welding
<ol style="list-style-type: none"> 1. As power supply available is usually a.c a rectifier is required for d.c welding hence the cost is high. 2. Maintenance of a rectifier is somewhat difficult. 3. Operating cost of d.c equipments is high. 4. The electric energy consumption per Kg of deposited metal in d.c welding ranges between 6-10 kwh. 5. In case of d.c welding the no load voltage is low and hence safer in operation. 6. Heat produced is uniform. 7. Power factor is unity due to resistance. 8. Cheap electrodes can be used because no coated electrodes are used. 9. The arc produced is stable and is suitable for welding of non-ferrous metals. 	<ol style="list-style-type: none"> 1. For a.c welding, only transformer is required which is relatively cheap in cost. 2. Maintenance of transformer is less difficult. 3. Operation costs of a.c. equipments are low. 4. The electric energy consumption per Kg of deposited metal in a.c. welding is 3-4 Kwh. 5. In case of a.c welding, the no load voltage is high and hence somewhat dangerous in operation. 6. Heat produced is not uniform. 7. Power factor is low hence capacitors are required. 8. Only coated electrodes are used or expensive electrodes are used. 9. The arc produced is not so stable.

Syllabus of UNIT –III:**ILLUMINATION FUNDAMENTALS AND ILLUMINATION METHODS:**

Introduction, terms used in illumination, laws of illumination, polar curves, photometry, integrating sphere, sources of light.

Discharge lamps, MV and SV lamps – comparison between tungsten filament lamps and fluorescent tubes, Basic principles of light control, Types and design of lighting and flood lighting.

Introduction:

Light is the prime factor in the human life as well as activities of human beings ultimately depend upon the light. Where there is no natural light, use of artificial light is made. Artificial lighting produced electrically, on account of its cleanness, ease of control, reliability, steady output, as well as its low cost it is playing an increasingly important part in modern every day life. The science of illumination engineering is, therefore, becoming of major importance.

Nature of light:

Light is a form of radiant energy. Various forms of incandescent bodies are the sources of light and the light emitted by such bodies depend upon the temperature of bodies. Heat energy is radiated into the medium by a body which is hotter than the medium surrounding it. The heat of the body, as seen, can be classified as red hot or white-hot. While the body is red-hot the wave length of radiated energy will be sufficiently large and the energy available is in the form of heat. When the temperature increases the body changes from red-hot to white-hot state, the wave length of the energy radiated becomes smaller and smaller and enter into the range of the wave length of the light.

Colour: The sensation of colour is due to the difference in the wave lengths of the light radiations. Visible light can have wave lengths of the light between 4,000Å and 7,500Å

Relative sensitivity:

The sensitivity of the eye to the lights of different wave lengths varies from person to person and according to the age. The average relative sensitivity is shown in the following figure. The eye has greatest sensitivity for wave lengths of about 5,500Å: that is yellow-green can be seen under such poor conditions of illumination when blue or red can not be seen under dim illumination, the sensitive curve shifts as shown by the shaded region in the following figure. Therefore, violet disappears first and red remains visible. Yellow disappears last as the illumination becomes very dim. As each colour disappears, it becomes a grey shade and finally black. The sensitivity of eye to yellow-green radiation is taken as unity or 100% and the sensitivity to other wave lengths is expressed as a fraction or percentage of it. The relative sensitivity at a wave length λ is written k_{λ} and is known as *relative luminosity factor*.

Illumination:

Illumination differs from light every much, though generally these terms are used more or less synonymously. Strictly speaking light is the cause and illumination is the result of that light on surfaces on which it falls. Thus the illumination makes the surface look more or less bright with certain colour and it is this brightness and colour which the eye sees and interrupts as something useful or pleasant or other wise.

Light may be produced by passing electric current through filaments as in the incandescent lamps, through arcs between carbon or metal rods, or through suitable gases as in neon and other gas tubes. In some forms of lamps the light is due to fluorescence excited by radiation arising from the passage electric current through mercury vapour.

Some bodies reflect light in some measure, and when illuminated from an original source they become secondary source of light. The good example is the moon, which illuminates earth by means of the reflected light originating in the sun.

Terms used in illumination:

The modern lighting schemes and the selection of fittings and type of lamps require knowledge of the terms and quantities in general use for such purposes. Therefore, the following definitions are given in simple form to facilitate easy identification and reference.

Light: It is defined as the radiation energy from a hot body which produces the visual sensation upon the human eye. It is usually denoted by Q , expressed in lumen-hours and is analogous to watt-hour.

Luminous flux: it is defined as the total quantity of light energy emitted per second from a luminous body. It is represented by symbol F and is measured in lumens. The concept of luminous flux helps us to specify the output and efficiency of a given light source.

Luminous intensity: luminous intensity in any given direction is the luminous flux emitted by the source per unit solid angle, measured in the direction in which the intensity is required. It is denoted by symbol I and is measured in candela(cd) or lumens/steradian.

If F is the luminous flux radiated out by source within a solid angle of ω steradian in any particular direction then $I = \frac{F}{\omega}$ lumens/steradian or candela (cd).

Lumen: the lumen is the unit of luminous flux and is defined as the amount of luminous flux given out in a space represented by one unit of solid angle by a source having an intensity of one candle power in all directions.

$$\text{Lumens} = \text{candle power} \times \text{solid angle} = \text{cp} \times \omega$$

Total lumens given out by source of one candela are 4π lumens.

Candle power: Candle power is the light radiating capacity of a source in a given direction and is defined as the number of lumens given out by the source in a unit solid angle in a given direction. It is denoted by a symbol **C.P.**

$$C.P. = \frac{\text{lumens}}{\omega}$$

Illumination: When the light falls upon any surface, the phenomenon is called the illumination. It is defined as the number of lumens, falling on the surface, per unit area. It is denoted by symbol **E** and is measured in lumens per square meter or meter-candle or lux.

If a flux of **F** lumens falls on a surface of area **A**, then the illumination of that surface is $E = \frac{F}{A}$
lumens/m² or lux

Lux or meter candle: It is the unit of illumination and is defined as the luminous flux falling per square meter on the surface which is every where perpendicular to the rays of light from a source of one candle power and one meter away from it.

Foot candle: It is also the unit of illumination and is defined as the luminous flux falling per square foot on the surface which is every where perpendicular to the rays of light from a source of one candle power and one foot away from it.

$$1 \text{ foot-candle} = 1 \text{ lumen/ft}^2 = 10.76 \text{ meter candle or lux}$$

Candle: It is the unit of luminous intensity. It is defined as $\frac{1}{60}$ th of the luminous intensity per cm² of a black body radiator at the temperature of solidification of platinum (2,043⁰K).

Mean horizontal candle power: (M.H.C.P) It is defined as the mean of candle powers in all directions in the horizontal plane containing the source of light.

Mean spherical candle power: (M.S.C.P) It is defined as the mean of the candle powers in all directions and in all planes from the source of light.

Mean hemi-spherical candle power: (M.H.S.C.P) It is defined as the mean of candle powers in all directions above or below the horizontal plane passing through the source of light.

Reduction factor: Reduction factor of a source of light is the ratio of its mean spherical candle power to its mean horizontal candle power.

$$\text{i.e reduction factor} = \frac{M.S.C.P}{M.H.C.P}$$

Lamp efficiency: It is defined as the ratio of the luminous flux to the power input. It is expressed in lumens per watt.

Specific consumption: It is defined as the ratio of the power input to the average candle power. It is expressed in watt per candela.

Brightness or luminance: When the eye receives a great deal of light from an object we say it is bright, and brightness is an important quantity in illumination. It is all the same whether the light is produced by the object or reflected from it.

Brightness is defined as the luminous intensity per unit projected area of either a surface source of light or a reflecting surface and is denoted by L.

If a surface area A has an effective luminous intensity of I candelas in a direction θ to the normal, then the brightness (luminance) of that surface is

$$L = \frac{I}{A \cos \theta} \text{ candela/m}^2 \text{ or nits}$$

Nit is defined as the candela per square meter. Bigger unit of brightness (luminance) is Stilb which is defined as candelas per square cm. lambert is also the unit of brightness which is lumens/cm². Foot lambert is lumens/ ft².

Glare:- The size of the opening of the pupil in the human eye is controlled by its iris. If the eye is exposed to a very bright source of light the iris automatically contracts in order to produce the amount of light admitted and prevent damaged to retina this reduces the sensitivity, so that other objects within the field of vision can be only imperfectly seen. In other words glare maybe defined as brightness with in the field of vision of such a character as the cause annoyance discomfort interference with vision.

Space height ratio:- it is defined as the ratio of distance between adjacent lamps and height of their mounting.

$$\text{Space height ratio} = \frac{\text{horizontal distance between two adjacent lamps}}{\text{mounting height of lamps above working plane}}$$

Utilization factor or co-efficient of utilization:- It is defined as the ratio of total lumens reaching the working plane to total lumens given out by the lamp.

$$\text{Utilization factor or co-efficient of utilization} = \frac{\text{total lumens reaching the working plane}}{\text{total lumens given out by the lamp}}$$

Maintenance factor: Due to accumulation of dust, dirt and smoke on the lamps, they emit less light than that they emit when they are new ones and similarly the walls and ceilings e.t.c. after being covered with dust, dirt and smoke do not reflect the same output of light, which is reflected when they are new.

The ratio of illumination under normal working conditions to the illumination when the things are perfectly clean is known as maintenance factor.

$$\text{Maintenance factor} = \frac{\text{illumination under normal working conditions}}{\text{illumination when every thing is clean}}$$

Depreciation factor: this is merely reverse of the maintenance factor and is defined as the ratio of the initial metre-candles to the ultimate maintained metre-candles on the working plane. Its value is more than unity.

Waste light factor: Whenever a surface is illuminated by a number of sources of light, there is always a certain amount of waste of light on account of over-lapping and falling of light outside at the edges of the surface. The effect is taken into account by multiplying the theoretical value of lumens required by 1.2 for rectangular areas and 1.5 for irregular areas and objects such as statues, monuments etc.

Absorption factor: In the places where atmosphere is full of smoke fumes, such as in foundries, there is a possibility of absorption of light. The ratio of total lumens available after absorption to the total lumens emitted by the source of light is called the absorption factor. Its value varies from unity for clean atmosphere to 0.5 for foundries.

Beam factor: the ratio of lumens in the beam of a projector to the lumens given out by lamps is called the beam factor. This factor takes into the account the absorption of light by reflector and front glass of the projector lamp. Its value varies from 0.3 to 0.6.

Reflection factor: When a ray of light impinges on a surface it is reflected from the surface at an angle of incidence, as shown in the following figure. A certain portion of incident light is absorbed by the surface. The ratio of reflected light to the incident light is called the **reflection factor**. It's value always less than unity.

Solid angle: Plane angle is subtended at a point in a plane by two converging straight lines and its magnitude is given by

$$\theta = \frac{\text{arc}}{\text{radius}} \text{ radians}$$

The largest angle subtended at a point is 2π radians.

Solid angle is the angle generated by the surface passing through the point in space and the periphery of the area. Solid angle is denoted by ω , expressed in steradians and is given by the ratio of the area of the surface to the square of the distance between the area and the point.

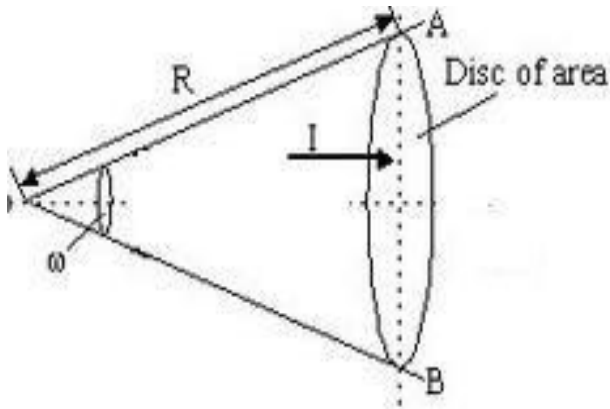

$$\text{i.e } \omega = \frac{\text{Area}}{(\text{Radius})^2} = \frac{A}{r^2}$$

The largest solid angle subtended at a point is that due to a sphere at its centre. If r is the radius of any sphere, its surface area is $4\pi r^2$ and the distance of its surface area from the centre is r , therefore, solid angle subtended at its centre by its surface, $\omega = \frac{4\pi r^2}{r^2} = 4\pi$ steradians.

Steradian: It is the unit of solid angle and is defined as the solid angle that subtends a surface on the sphere equivalent to the square of the radius.

Laws of illumination:- There are two laws of illumination

1. Law of inverse squares
2. lamberts cosine law

1. Law of inverse squares:- If a source of light which emits light equally in all directions be placed at the center of the hallow sphere, the light will fall uniformly on the inner surface of the sphere that is to say, each square mm of the surface will receive the same amount of light. If the sphere be replaced by one of the larger radius, the same total amount of light is spread over a larger area proportional to the square of the radius. The amount which falls upon any square mm of such a surface will therefore diminishes as the radius increases, and will be inversely proportional to the square of the distance

A similar relation holds if we have to deal with a beam of light in the form of a cone or pyramid as shown in the fig. if we consider parallel surfaces which cut the pyramid at different distances from the source, the areas of these surfaces are proportional to the square of these distances, and therefore the amount of light which falls on the one unit of the area of these surfaces is inversely proportional to the square of the distances from the source.

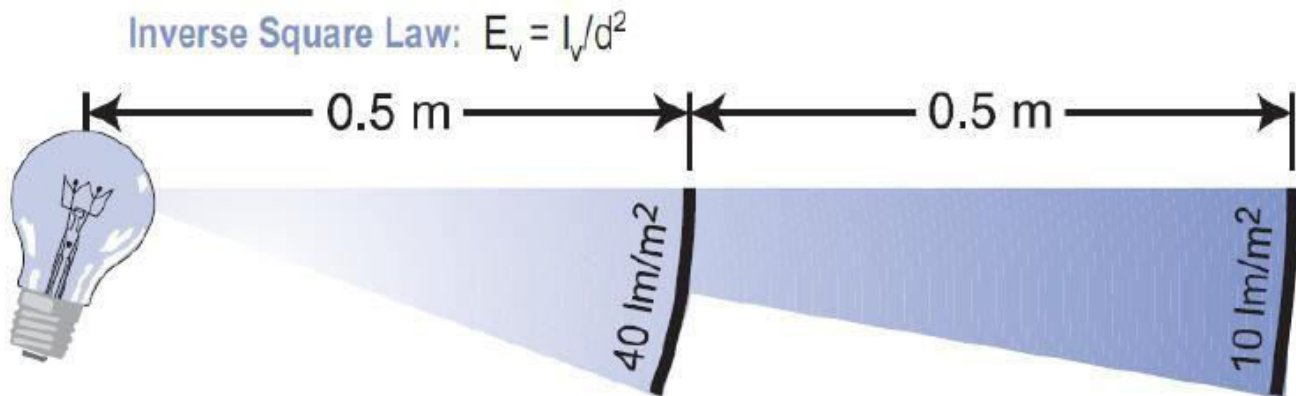

➤ **Polar curves** :-

All over discussions so far were based on the assumption that luminous intensity or the candle power from a source is uniformly distributed over the surrounding surface. But none of the practical type of lamp gives light uniformly distributed in all directions because of its unsymmetrical shapes. It is often necessary to know the distribution of light in various directions to ascertain how the candle power of light source varies in different directions. The luminous intensity in all directions can be represented by polar curves. If the luminous intensity in a horizontal plane passing through the lamp is plotted against angular position, a curve known as horizontal polar curve is obtained. If the luminous intensity in a vertical plane is plotted against the angular position, a curve known as vertical polar curve is obtained. The typical polar curves for an ordinary filament lamp are shown in the following fig:

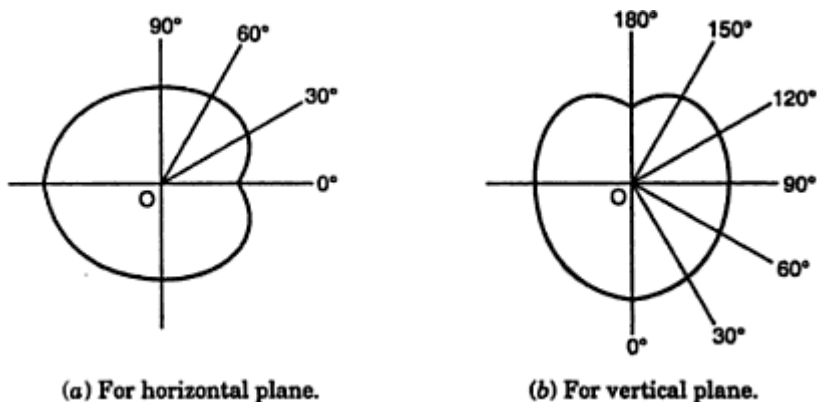

The polar curves are used to determine the mean horizontal candle power (m.h.c.p.) and mean spherical candle power (m.s.c.p.). these are also used to determine the actual

illumination of a surface by employing the candle power in that particular direction as read from the vertical polar curve in the illumination calculations.

The mean horizontal candle power of a lamp can be determined from the horizontal polar curve taking the mean value of the candle power in a horizontal direction.

Mean spherical candle power can be determined from the vertical polar curve by Rousseau's construction.

Rousseau's construction: The construction is illustrated in the following figure. A semi circle of any convenient radius is drawn with the pole of the polar diagram as centre. The line CD is drawn equal and parallel to the vertical diameter YY¹. Now from this line CD ordinate equal to corresponding radius on the polar curve are set up such as BD = OK, GH = Of and so on. The curve obtained by joining the ends of these ordinates is known as Rousseau's curve. The mean ordinate of this curve gives the m.s.c.p. of the lamp having polar curve given as in the following figure.

$$\text{The mean ordinate of the curve} = \frac{\text{Area CSTGDBHLC}}{\text{Length of CD}}$$

The area under the curve can either be determined on the graph paper or found by Simpson's rule.

Photometry: -

The candle power of a source in any given direction is measured by comparison with a standard or substandard source employing photometer bench and some form of photometer. The experiment is performed in dark room with dead black walls and ceiling in order to eliminate the errors due to reflected light.

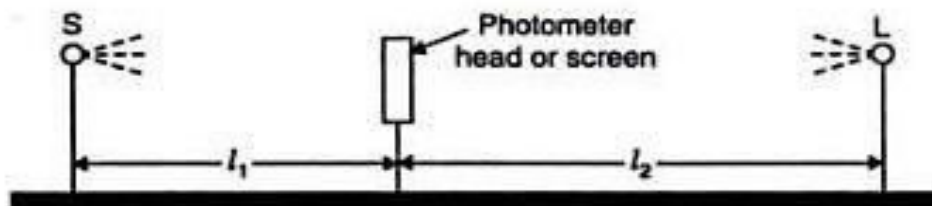

S = Standard source (known C.P.)

L = Lamp under test.

Photometer bench for measurement of candle power.

The photometer bench consists essentially of two steel rods which carry the stands or saddles for holding the two sources, the carriage for the photometer head and for any other operators employed in making measurements. One of the bar carries a bar strip, graduated in centimeters and milli-meters the carriages which slides upon the bench have expect that carrying the photometer head, a circular table which can be rotated in a horizontal plane and clamped in any position. The circular table is provided with a scale graduated in degrees round its edge so that the angle of rotation of lamp from the direction of the axis of bench can be measured. The bench should be rigid so that the source is being compared may be free from vibrations and carriage holding the photometer head should be capable of moving smoothly and with every little effort. The photometer head acts as a screen for comparison of illumination of the standard source and the source under test. There are different types of photometers, which can be used for the purpose. Some of them are described here.

The principle of the most methods of measurement is based upon the inverse square law.

The standard source, whose candle power is known (say S) and the source under test whose candle power is to be determined, are set on the bench at a distance apart with some type of screen in line with, and between, them as shown in the above figure. The photometer head or screen is moved in between the two fixed sources until the illumination on the both sides of the screen is same. If the distance of the standard source S and source under test T from photometer head are l_1 and l_2 respectively then according to inverse square law.

$$\frac{\text{Candle power of source under test}}{\text{Candle power of standard source}} = \frac{l_2^2}{l_1^2}$$

$$\text{Candle power of source under test} = S \times \frac{l_2^2}{l_1^2}$$

➤ **Integrating sphere:-**

It is a source of apparatus which is now commonly employed for measurements of mean spherical candle power. In this method the sphere is used to measure the total flux radiated by the lamp, which when divided by 4π gives as m.s.c.p. Since in this method the flux radiated in all directions is taken into account, so this method is better than that described in which it was assumed that the candle power distribution is same in all vertical planes, an assumption which may not always be justifiable.

The integrating sphere consists of a hollow sphere whose diameter is large compared to the lamp to be tested having a smooth inner surface with a uniform coating of white paint. If the lamp is hung inside the sphere, the light is so diffused an uniform illumination is produced over the whole surface. A small window of translucent glass provided at one side of the sphere is illuminated by reflecting light from the inner surface of the sphere. The small screen is inserted in between the lamp and window in order to prevent the light from the lamp reaching the window directly.

➤ **Source of light**:- According to the principle of operation of light source maybe grouped as follows:

1. **Arc lamps**: - Electric discharge through air gives intense light. This principle is utilized in arc lamps.
2. **High temperature**: - Oil and gas lamps and incandescent filament type lamps, which emit light when heated to high temperature.
3. **Gaseous discharge lamps**: - Under certain conditions it is possible to pass electric current through a gas or metal vapour, which is accompanied by visible radiation. Sodium and mercury vapour lamps operate on this principle.
4. **Fluorescent type lamps**:- Certain materials, when exposed to ultra violet rays, the absorbed energy into the radiation of longer wave length lying within the visible range. This principle is employed in fluorescent lamps.

Syllabus of UNIT –IV:**ELECTRIC TRACTION – I,II**

System of electric traction and track electrification. Review of existing electric traction systems in India. Special features of traction motor, methods of electric braking-plugging rheostatic braking and regenerative braking. Mechanics of train movement. Speed-time curves for different services – trapezoidal and quadrilateral speed time curves.

Various systems for Traction:**1. Steam Locomotive :**

This consists of a steam boiler which produces superheated steam at a pressure of 10 to 15 kg/cm². This steam drives two double acting, non-condensing steam engines which provide the motive power for the train. The speed is controlled by regulating the flow of steam to the engine.

These engines have now become obsolete and are being gradually withdrawn from services.

2. Diesel Engines :

In these engines a multi cylinder diesel engine is. coupled to a dc generator which supplies power to the dc traction motors. These engines are available in 450 HP (shunter) to 2500 HP range. These are manufactured at Diesel Locomotive Workshops.

These engines can be easily started from cold conditions. Their availability is higher as compared to a steam engine. Also these engines have better a overall efficiency (around 25%) as compared to about 5 to 10 percent for steam locomotives.

3. Electric traction :

Here power is applied to the vehicle from an overhead wire suspended above the track.

Electric traction systems may be broadly categorized as those operating on :

1. Alternating current supply
2. Direct current supply.

In general following electric traction systems exist :

- (A) AC 3 phase 3.7 kV system
- (B) AC single phase 15/16 kV -161/25 Hz

- (C) AC single phase 20/25 kV - 50/60 Hz
- (D) DC 600 V
- (E) DC 1200 V
- (F) DC 1.5 kV
- (G) DC 3 kV.

Electric Traction :Advantages :

Electrical transmission, which is usually applied to high power units, has following advantages:

1. It has smooth starting without shocks.
2. Full driving torque is available from standstill.
3. Engine can be run at its most suitable speed range. This given higher efficiency range.
4. Characteristics of traction motor and generator are so chosen that the speed of the traction unit automatically adjusts according to the load and gradient so as to maintain constant output and not to overload the diesel engine.
5. Electrical transmission does not only work as torque converter but also works as reversion gear.

ELECTRIC TRAINS:

Electric trains can be run on a.c & d.c.In early days d.c at 1,500v &1-φ a.c at 11 to 15kv having frequency 25 c/s or 16 2/3 c/s were used .However d.c was preferred as compared to a.c because in case of a.c an additional equipment is required to convert normal frequency 50 c/s to 25c/s or 16 2/3 c/s.

Later on a.c has proved more advantages in terms of ohmic losses .Moreover in cases of a.c higher voltages can be obtained by use of transformer which reduces the losses and thus increases the spacing between two substations thereby reducing the number of feeding substations .In case of 3-φa.c normal frequency i.e 50c/s is employed for traction thereby by eliminating low frequency difficulty.

COMPARISION BETWEEN D.C TRACTION AND D.C TRACTION:

1.	In D.C traction ,D.C series motor develop more starting and running torque and arc capable of giving high acceleration and retardation.	1.	In A.C trains , starting and running torque developed by a.c motor of same size less and hence acceleration and retardation

2.	Number of speeds obtained by d.c motor is limited except by chopper method	2.	Number of speeds obtained are many by tap changing method
3.	D.C series motor are cheap, lighter & more efficient	3.	A.C motors are somewhat expensive and less efficient
4.	In case of d.c ,the overhead distribution is lighter and less costly as the losses.	4.	In case of a.c ,the overhead distribution is heavy and thus expensive
5.	D.C System produces less interference with communication lines	5.	A.C System produces more interference with communication lines
6.	For a given length of track the number of substations required is more as the voltage above prescribed	6.	For a given length of track the number of substations required is less as the voltage above prescribed
7.	D.C .motors requires less maintenance	7.	A.C .motors requires MORE maintenance

TRACK ELECTRIFICATION:

Following systems are usually employed for track electrification:

1. D.C system
2. Single phase a.c system
3. Three phase a.c system
4. Composite system

D.C system:

In this system ,the energy is obtained from the substations which consists of transformers and converting equipments like SCR's .The motor employed for getting the necessary propelling torque are usually d.c series motor because of their high starting torque .However compound motor are also coming into favour for tramways & trolley buses where regenerative braking is required .The operating voltage is 600v for tramways and trolley buses whereas it is 1500-3000v for main line railways.

The system consists of a contact wire and a running rail (which act as a return conductor)in case of tramway and two contact wires in case of trolley buses fed from substations which are suitably spaced depending upon the operating voltage The Usual practice is to feed the substation with arc at 33kv to 100kv and substation is

equipped with transformer to reduce the voltage to desired value and rotator converters to convert arc to o.k. the use of high arc voltage reduces the cost of transmission lines and copper losses,

Merits:

1. D.C motors have better characteristics as compared to arc traction motor.
2. Maintenance cost of D.C. motors is low.
3. The weight per kiwi output of o.k. motor is less as compared to arc motor.

Demerits:

1. Due to low operating voltage as compared to arc conductor of large cross section for distribution is required and thus number of substations to be erected will be more for given service.
2. Cost of substations required for the system is high due to heavy cost of converting equipment required for converting arc to D.C and of additional equipment such as negative boosters to keep the voltage to return rail within the limits.

APPLICATIONS:

The D.C. system is preferred for suburban services and road transport where there are frequent stops.

SINGLE PHASE A.C SYSTEM:

In single phase arc system , arc series motors are used for getting the necessary motive power. The voltage employed for distribution network in this system is 15,000-25,000v at normal frequency which is steeped down to 300v-400v at $16\frac{2}{3}$ or 25hz by use of a step down transformer frequency. The change of frequency is necessary as a./c series motors performs better at low frequency since low frequency improves commutation ,puff and efficiency . The adjacent spacing between two substations is usually taken as 50-80 km because of low current requirement at high voltage.

If the traction system is supplied by generating stations exclusively meant for the purpose, there is no difficulty in having electric supply of $16\frac{2}{3}$ or 25cycles. If however electric supply is taken from industrial frequency network which is usually the case, substations in addition to transformers has necessary to have frequency convertor equipment which consists of three phase synchronous alternator set which takes power at three phase and supplies load of single phase low frequency apart from reducing voltage drop in rails also reduce telephonic interference.

This system is invariably adopted where cost of over head structure is of more importance as high voltage at low frequency reduces the cost of overhead structure because of line reactance and high voltage transmission.

THREE PHASE A.C SYSTEM:

In this system, energy can be drawn directly from existing three phase network by using transformer substation is the case the network is operating at higher voltage. The s propelling power is obtained from 3 phase induction motor operating at 3,300 to 3,600v at normal or $16\frac{2}{3}$ frequency. This system usually consists of two overhead conductors and track rail acts as third phase. This system has high efficiency as no converting equipments are employed.

The few drawbacks of induction motors are low starting torque high stating current and absence of speed control due to which the three phase system could not be popular.

Thus three phase system is employed in some hilly areas where power required is high due to slopes and regeneration on large scale is possible.

DISADVANTAGES:

1. Two over head conductors feeding the system becomes very much complicated at crossings and junctions.
2. Constant speed characteristics of induction motor is not suited on traction work. However, locomotives having four speeds have been designed using cascade connections and pole changing method of speed control.
3. Induction motors have speed torque characteristics similar to d.c shunt motor .this is not suitable for parallel operation as with little difference in rotational speed caused due to unequal diameters of the wheels, motors are loaded so differently .

COMPOSITE SYSTEM:

A.C system is preferable from the point of distribution and contact wire system as the voltage can be stepped up to high value by the use of transformers which not only reduces the losses but also the cost of distribution networks where as in d.c system d.c series motor have most desired features of traction and hence it is ideally suitable. has some efforts been made to combine advantages of a.c ,d.c and {3phase / 1phase} system.

(a) SINGLE PHASE TO THREE PHASE SYSTEM (Kando System):

In this system single high voltage is employed for distribution purposes and 3 phase induction motors for getting the necessary driving power. Single phase supply is used for distribution purposes as the single phase over head distribution system is cheap where as three phase induction motor are simple and robust in construction with high operating efficiency with additional provision of regenerative braking. The voltage used for distribution network is about 15,000v at 50hz. The locomotive carries a phase convertor for converting three phase supply to single phase supply. The development of silicon controlled rectifier used as inverter made possible to get variable low frequency supply (1/2 to 9 hz) at which induction motor develops high starting torque without excessive current and speed control is also conveniently obtained by varying the supply frequency.

(b) single phase to d.c :

In this system the advantage of two systems are combined together i.e. high voltage single phase for distribution and d.c series motor for producing necessary tractive effort are employed single arc distribution results in high efficiency of transmission with minimum cost whereas the d.c series is ideal for traction .The locomotive carries transformer to step down voltage and converting machinery to convert into d.c . The voltage employed for distribution is 25kv at normal frequency 50hz and this method of track electrification is employed in our country.

Advantages:

1. At constant power, due to high system voltage used , the line current decreases thereby decreasing the cross section of the overhead conductors eventually leading to the saving in cost of conductors and supporting structures.
2. On account of high voltage ,the substation can be spaced at longer distances which results in substantial saving in capital expenditure due to number of substations to be erected.
3. A.C substations are cheaper as they have only step down transformer and associate with switch gear. They donot require any additional conversion equipment.

4. The starting efficiency of a.c locomotive is higher to that d.c as d.c locomotives start employing starting resistors which results .in increased ohmic losses due to which the efficiency goes down where as a.c locomotive employ tap changers either on primary or secondary of transformers for starting.
5. D.C series motor have ideal traction characteristic for getting required propelling power therefore this system have got the advantages of d.c system.

TYPES OF SERVICES:

The selection of any suitable system can be made if we know the requirement of various types of railway service.

There are three types of passenger services which traction system has to cater for namely urban suburban and main line services.

i) MAIN LINE SERVICE :

The distance between two stations in this service is more than 10kms. The most important requirements of main line railway service are:

1. High speed
2. Minimum cost of over head structure.
3. Acceleration and retardation are not so important for main line service.

ii) SUB URBAN SERVICE:

The distance between two sub urban service between 1-8 kms . the most important requirements of this type of service are :

1. Rapid acceleration and retardation as frequent starting and stopping is required.
2. The voltage fluctuations should not affect the working of motors.
3. No interference to communication lines running along the track.

The d.c system fulfil all the above requirements and therefore invariably adopted due to the following advantages.

1. Under similar conditions the energy consumption in d.c system is less as compared with that in a.c system.
2. For exerting the same torque. Current required in d.c system is less than that in a.c system.
3. The d.c locomotive and motor coach equipment is lighter in weight, cheaper initial as well as in maintenance cost and more efficient.

However there are certain disadvantages associated with it and they are :

1. Due to low voltage employed for distribution purpose , the current required high and therefore section of the conductor required is large , the spacing substations required is less and number of substations required is more.
2. Substations are more costly as converting machinery is required.
3. Efficiency of substation is less.
4. Additional equipment such as negative booster etc. is required for keeping the voltage of return rail within limits

iii) URBAN SERVICE:

The distance between two consecutive stops is less than 1 km . the most important requirement of urban service are:

1. Relatively high speed so that good frequency of train is made available
2. High values of acceleration and retardation are maintained with a short period coasting in order to obtain a reasonable saving or energy consumption.

REVIEW OF EXISTING ELECTRIC TRACTION SYSTEM IN INDIA:

Electric traction was first introduced in Britain in the year 1890 at 600v d.c but in India the electrification was done in the year 1925. the first sub urban service was laid between Bombay v.t to Igatpuri and Poona and the power was supplied at 1500v d.c from rotary convertor sub stations which were replaced in the rid controlled mercury arc rectifiers . now a days solid state devices are finding increasing use in the d.c substations .

After about 20yrs electric traction was introduced on 3000v d.c because of the general trend 3000v adopted by other countries from the reports obtained from French international railways on relative merits and demerits of a.c and d.c system,it was found that a.c system using industrial frequency was advantageous both financially and operationally and thus the Railway board in 1957 adopted 25kv ,50hz single phase system for all future schemes. This system gives considerable saving in cost of over head equipment, substations and locomotives.

So far with track electrification, INDIA occupies second position in Asia and eleventh position in the world.

AT PRESENT THE FOLLOWING SYSTEM OF ELECTRIFICATION ARE EMPLOYED:

- a. There are some systems which are continuing with d.c supply and voltages used are 600v, 1500v or 3,000v.
- b. A.C both single phase and poly phase with voltage of 15 to 25 kv at 162/3 c/s or 50c/s with single phase and 3300v to 3600v at 162/3 c/s
- c. Composite system in which the locomotives is supplied with a.c for its motor generator sets and these generators provide direct current to traction motors. the arc may be single phase or three phase supply.

SPECIAL FEATURES OF TRACTION MOTORS:

The motors required for traction work must meet the following requirements under two headings :

1.MECHANICAL FEATURES:

1. As the motor has to with stand the vibrations continuously due to the severe service conditions therefore motor should be robust.
2. The traction motor is located underneath a motor coach whose space is limited thus the motor must be small in overall dimensions specially in overall diameter.
3. As the motor is provided beneath the coach there is a possibility of ingress of dirt,dust,mud ,water etc. thus the motor must be totally enclosed type .
4. The motor should have min possible weight.

Use of cast steel is preferred for magnetic circuit of traction motor in comparison of cast iron as it gives good mechanical strength.

2.ELECTRICAL FEATURES:

1. A traction motor must have high starting torque especially when the train is to be accelerated at high rate.
2. The traction motor must be amenable to simple speed control methods as the electric train has to be started and stopped very often.
3. The speed of the motor should fall with the increase in the load which in turn prevents the excessive loading as power output =torque*speed.
4. The motor should be capable of withstanding high voltage fluctuations In supply voltage since the traction motor is subjected to rapid voltage fluctuations owing to heavy starting current.
5. It should be possible to employ rheostatic or regenerative braking .
6. Traction motors should be capable to withstanding temporary interruptions at the instant of crossing over the cross overs and section insulators.
7. Traction motor should be capable of taking excessive load as it is subjected to very arduous duty.

Most suitable motors which meet the all most all above requirements are d.c series motors and compound in case of d.c system where single phase a.c series and three phase induction motor in case of a.c system .

D.C SERIES MOTOR :

The d.c series motor is suitable for traction due to following characteristics of series motors which are prerequisites for traction service.

1. d.c series motor develops high starting torque which is an essential requirement for traction service.
2. They are robust and simple in construction.
3. In traction work usually more than one motor are required. They should have suitable speed torque and current torque characteristics which when run in parallel must not result in wide difference in the torque developed and current drawn as it may result in the unequal wear of driving wheels .
4. In case of d.c series $N \propto (E_b / \Phi) \propto (E_b / i)$

Assuming flux is proportional to exciting voltage

$$T \propto \Phi I \propto I^2$$

$$I = \sqrt{T}$$

Substituting (2) in (1)

$$N \propto (E_b / I) \propto (E_b / \sqrt{T})$$

We know that power output of a motor $\propto TN$

$$\text{Thus power output } T \propto (E_b / \sqrt{T}) \propto \sqrt{T} E_b$$

From the above equation it is evident that for a given increase in torque there is no increasing in h.p to corresponding degree.

5. series motor is amenable to various speed control methods
6. With the increase in armature current the load torque also increases which in turn decreases the speed which reduces the magnitude of emf induced in the coils undergoing commutation and thus replacement of brushes and commutator is prevented.
7. In series motors flux varies as armature current and torque corresponding to the given armature current is independent of voltage and thus the motor is unaffected by variations in supply voltage.
8. we know that up to magnetic saturation, $T \propto I^2$ i.e for a given increase in load torque, the power input required is comparatively very less and thus the motor are capable of withstanding excessive loads.
9. Since the time constant of series motor field flux will die in short time with the result the counter emf of motor ceases with temporary interruption of supply.

Thus the series motors are better suited for urban and suburban services where high rate of acceleration is required which can be met by connecting them in series permanently.

In 1500v d.c system the d.c series motor may be operated either at 1500v or 750v by connecting them in series permanently.

Drawbacks of d.c series motor are limitation of size of commutator owing to restricted speed, voltage and current and also there is a risk of flash over and the brush gear requires considerable maintenance.

A.C SERIES MOTOR:

Some of the Modifications for a.c series motors are as follows:

1. All the parts of magnetic circuit of an a.c. series motor are laminated in order to reduce eddy current losses.
2. The armature coils are single turn coils and brush of less width are used in order not to short circuit more than two coils at time.
3. The operating voltage is kept low order to reduce the inductance because high voltage motor with proportionally low current would require a large number of turns to produce the given flux.
4. Since inductive reactance is directly proportional to the frequency so a.c. series motors operating characteristics are better at low frequencies.

The single phase a.c. series motor has practically the same operating characteristics as d.c. series motor. The torque or tractive effort varies nearly as square of current and the speed varies inversely as the current

Single phase a.c. series motor which can be built in size up to several hundred KW are usually employed for electric traction work. The voltage is limited to about 300v and the weight is $1 \frac{1}{2}$ to 2 times that of a d.c motor. The power factor at starting torque is much lower than that of a d.c motor and a.c series motor and therefore not suited for suburban service with frequent stops. However they are extensively used for main line work where high acceleration is not important.

The low voltage required for motor is obtained from step down transformer with different tappings. At start, low voltage is applied across the motor. With the increase in speed the voltage is gradually

increased. At start higher torque is required , and as the torque reduces the current decreases and speed increases automatically because of series characteristics of motor

THREE PHASE INDUCTION MOTOR:

The three phase induction motor has following advantages

1. Simple and robust construction
2. Trouble free operation
3. Less maintenance.
4. High voltage operation consequently needing reduced amount of current and automatic regeneration.

In addition to above advantages, induction motor suffers from following drawbacks:

1. Flat speed torque characteristics.
2. Constant speed operation
3. Low starting torque.
4. Drawing high starting and complicated speed control systems.

With the development of variable frequency voltage such as inverters, cyclo converter some of the above disadvantages has been overcome.

1. Starting current of motor decreases when motor is started at low frequency
2. Induction motor gives good p.f and good efficiency at the speed near to synchronous speed of the motor .In conventional method of speed control change of slip method is used which employs low speed of motor or at high value of slip rotor losses will be more thereby decreasing efficiency. To get good efficiency and good p.f. synchronous speed of the motor itself is brought to lower speed by using variable frequency supply.

When 3 Φ induction motor is used , distribution system consists of two overhead wires and track rail for third phase to feed power to locomotive . Which gives a complicated overhead structure and also a person who comes in contact of third live wire might be in danger. Which can be overcome by kando system i.e. supply is given to locomotive with the help of single phase overhead wire which converted to three phase supply with the help of phase converter and fed to the motor.

REGENERATIVE BRAKING:**ADVANTAGES OF REGENERATIVE BRAKING:**

1. In regenerative braking , a part of braking energy is converted to electrical energy and is fed back to supply. Thus the consumption of energy is considerably (20-30%) reduced thereby affecting a considerable saving in operation cost.

2. Higher value of braking retardation is obtained so that vehicle can be brought to rest quickly running time is considerably reduced.
3. The wear of the brake shoes and the wheel tyres is reduced to considerable extent and therefore their life is increased and the running time is considerably reduced.
4. Small amount of brake dust is produced when mechanical brakes are applied.
5. Higher speeds are possible while going down the gradients because the high braking retardation can be obtained with regenerative braking.
6. It enhances the running safely.

DISADVANTAGES:

1. Additional equipment is for control of regeneration for protection of equipment and machines, hence initial as well as maintenance cost is increased.
2. The d.c machines required incase of this type of braking are of large size and cost more and thus the weight of locomotive and thus the required mechanical strength and cost increases.
3. For bringing the train to standstill, the mechanical braking is required to be applied when the speed of the train has retarded to approximately 7 kmph.
4. Owing to the recuperated energy, the operation of the substation becomes complicated and difficult.

Regenerative braking is unsuitable for tramways and trolley buses as it increases the initial cost as well as enhance the operating problem whereas it is recommended for electric trains which are operating on hilly tracks.

CHARACTERISTICS OF VARIOUS TYPES OF SERVICES:

Main Line Service	Urban service	Sub urban Service
1.The distance between two stations in this service is more than 10 Km.	1.The distance between two stations in this service is between 0.75 to 1 Km.	1.The distance between two stations in this service varies between 1 – 8 Km.
2. The speed-time curve of main line comprises of free running and coasting periods which are long whereas the acceleration and braking periods are comparatively small.	2. The speed-time curve of urban service consists of acceleration, retardation and coasting (small period) whereas there is no free running period.	2.The speed-time curve of suburban consists of acceleration, retardation And comparatively long coasting period but no free running period.

3.The maximum speed that can be attained in this service is 160 Kmph.	3.The maximum speed that can be attained in this service is 120 Kmph.	3.The maximum speed that can be attained in this service is 120 Kmph.
4.The typical value of acceleration varies between 0.6 – 0.8 Kmphps.	4.The typical value of acceleration varies between 1.5 – 4.0 Kmphps.	4.The typical value of acceleration varies between 1.5 – 4.0 Kmphps.
5.The typical value of retardation is 1.5 Kmphps.	5.The typical value of acceleration varies between 3 – 4 Kmphps.	5.The typical value of retardation varies between 3 – 4 Kmphps.

Syllabus of UNIT –V:

ELECTRIC TRACTION-III:

Calculations of tractive effort, power, specific energy consumption for given run, effect of varying acceleration and braking retardation, adhesive weight and braking retardation adhesive weight and coefficient of adhesion.

SPEED-TIME CURVES:

A train is to be run between two stations optimally as far as possible. The movement of trains and their energy consumption can be conveniently studied by means speed-time and speed distance curve. Speed-time curve show the speed at various times after the start of run whereas the speed – distance curve shows the speed at various distances from starting point of the two i.e. speed – time and speed – distance curve is generally more useful as the slope of the curve represents the acceleration and the area under the curve ($\int V dt$) represents the distance travelled.

A curve plotted with time in seconds or minutes as abscissa and speed in Km/hr as ordinate is known as speed – time curve. This curve gives the complete information of motion of train – slope of the curve at any point gives the magnitude of acceleration or retardation. The upward slope indicates retardation.

SPEED –TIME CURVE FOR MAIN LINE SERVICE:

In the service, the distance between two stations is more than 10 Kms.

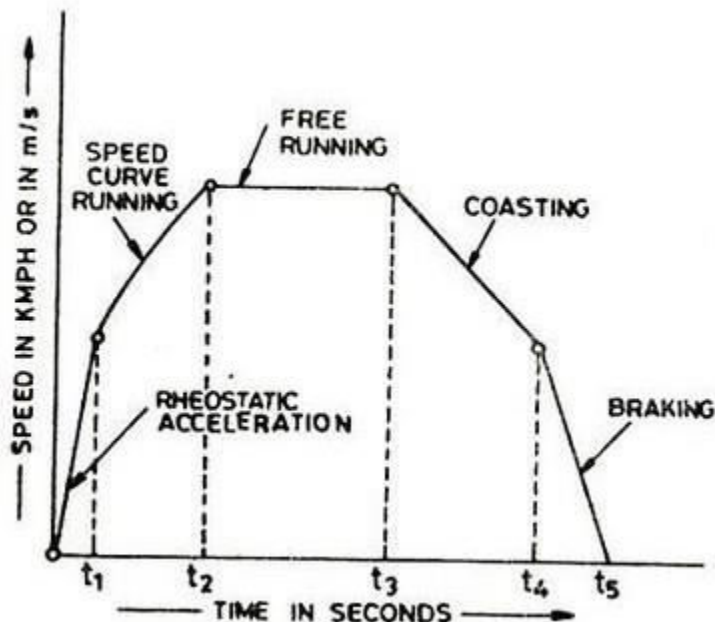

Speed – time curve mainly consists of

- (i) Initial acceleration

(ii) Constant speed run or free run

(iii) Costing

(iv) Retardation

Typical speed time curve for main line service is shown.

(i) Acceleration:

With electric trains using d.c series motors the period of acceleration consists of two parts namely:

(a) constant acceleration or acceleration while notching up

(b) decreasing acceleration.

(a) Constant Acceleration:

The acceleration of the electric train is maintained constant during starting period which is achieved by supplying approximately constant current. The voltage across the motor is gradually increased by cutting out the starting resistance with the help of starter by moving the starter handle period (0 – t_1) and acceleration is known as rheostatic acceleration. The typical value of acceleration varies between 0.6 – 0.8 Kmphps.

(b) Decreasing Acceleration:

During speed curve running (t_1 to t_2) the voltage acting across the motor remains constant and current starts decreasing with increase in speed according to the characteristics of the motor and finally the current taken by the motor becomes constant. During this period though the train accelerates but acceleration decreases with the increase in speed and finally becomes zero at the speed at which the tractive effort developed by the motor becomes exactly equal to the resistance to the motion of train.

(ii) Free Run or Constant Speed Run:

— At the end of speed curve running i.e., at t_2 the train attains maximum speed. During this period the train runs with constant speed attained at t_2 and thus the power drawn from the supply is constant.

(iii) Costing:

At the end of free running period (i.e., at t_3) power supply is cut off and the train will start running due to its momentum. Due to the frictional resistance to the motion, the speed of that train starts decreasing or in other words there will be a retardation during this period and this retardation is known as coasting retardation.

(iv) Retardation or Braking:

At the end of coasting period (i.e., at t_4) the brakes are applied to bring the train to rest. During this period the speed decreases rapidly and finally reduces to zero.

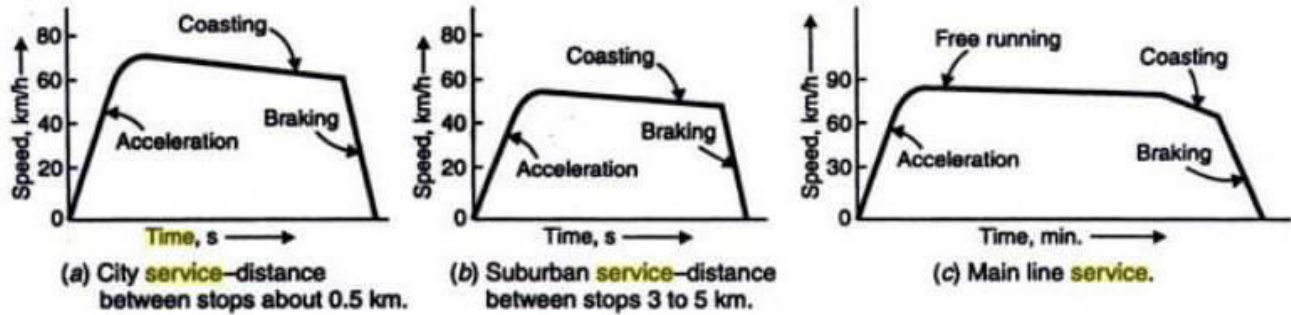

Fig. 7.2 (a, b, c) shows the typical **speed-time** curves for different services.

Refer to Fig. 7.2 (a). It represents **city service** where relative values of acceleration and retardation are high in order to achieve moderately high average **speed** between stops. Due to short distances between the steps, there is no possibility of free-running period though a short coasting period is included to save on energy consumption.

- Refer to Fig. 7.2 (b). Here, **suburban services** are represented in which again there is no free-running period but there is comparatively **longer coasting period** because of longer distances between stops. In this case also, relatively high values of acceleration and retardation are required in order to make the **service** as attractive as possible.
- Refer to Fig. 7.2 (c). It represents **main line service**. Here, there are long periods of free-running at high speeds. The acceleration and retardation periods are relatively less important.

DEFINITIONS OF THE IMPORTANT TERMS USED IN CALCULATION OF TRACTION:

In any calculations of train motion the following factors are considered:

1. **CREST SPEED:** It is the maximum speed attained by a train during run.
2. **AVERAGE SPEED:** It is the mean speed maintained by a train during a run. It is given as:

$$\text{Avg. speed} = \text{Distance between stops in km} / \text{Actual time of run in hr}$$
3. **SCHEDULE SPEED:** It is the ration of the distance between the stops and total time taken including time for stops to cover this distance i.e.,

$$\text{Schedule speed} = \text{distance between stops in km} / \text{Actual time of run in hr.} + \text{stop time in hr.}$$

The following factors affect the schedule speed of a train:

- (a) Crest speed or maximum speed
- (b) Acceleration
- (c) Retardation
- (d) Duration of stops.

(a) Crest speed:

For a constant run and with fixed acceleration and retardation the actual time of run will decrease with the increase in crest speed. The effort of variation in crest speed on schedule speed is considerable in case of long distance run i.e., if the distance between two stations is more, the high crest speed will reduce the time drastically.

(b) Acceleration:

If the distance between two stations and crest speed are constant then increase in acceleration will reduce the running time of the train. The increase in acceleration will increase the schedule speed. If the distance between two stations is small then increase will be considerable.

(c) Retardation:

With high braking retardation, the schedule speed of the train also increases. This effect will be considerable if the distance between stations is small.

(d) Duration of stop:

If the duration of stop is more, then the total running time will be more and thus the schedule speed will be low. Thus for high schedule speed duration of stop should be less. There it is recommended to have stop time of 15 to 20 seconds for small service to have a fairly good schedule speed whereas it is negligible in main line service.

Simplified Speed Time Curves**SIMPLIFIED SPEED-TIME CURVES**

- The speed-time curve of an *urban service* can be replaced by an equivalent speed-time of simple quadrilateral shape.
- The speed-time curve of a *main line service* is best and most easily replaced by a trapezoid.

Since the area of speed-time curve represents the total distance travelled hence the areas of the two curves should be same.

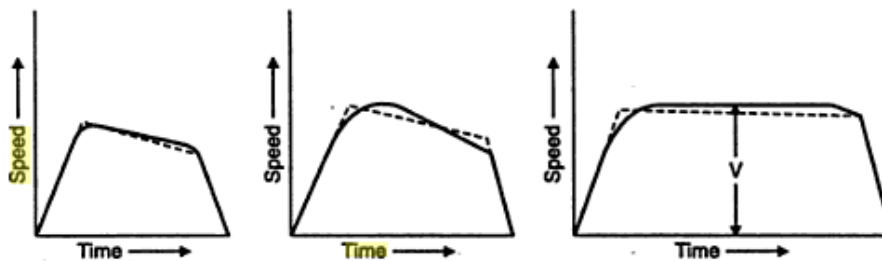

Approximate speed-time curves.

TRAPEZOIDAL AND QUADRILATERAL SPEED TIME CURVE:

For preliminary work and to study the performance of various speed time curves, the actual speed time curves are replaced by approximate curves. These curves have simple geometries and hence the relationship between the acceleration, retardation, average speed and distance can be deduced by simple mathematical calculations.

These simplified curves saves the labour in repeating the calculations over a large number of times and moreover such calculations can be made without much knowledge of the motor characteristics.

While drawing the approximate speed time curves the following are kept in mind:

- (i) The values of acceleration and retardation are kept same as those of original speed time curve.
- (ii) The speed – curve running and coasting periods of the actual speed time curve are replaced by a constant period(trapezoidal approximation).
- (iii) The initial acceleration period and the coasting periods are extended in the approximated curve(quadrilateral approximation).
- (iv) The area under the approximation curve and the actual speed time curve(distance between two stations)is same.

Trapezoidal curve is a ciose approximation to main line service where the duration for free running is long whereas quadrilateral curve is a better approximation to the actual conditions on urban and suburban runs where short distances are involved.

CALCULATIONS BY TRAPEZOIDAL SPEED TIME CURVE:

Trapezoidal curve is a close approximation to main line service where the duration for free running in long. The Trapezoidal curve OABC is shown in the below figure

- Let, D = Distance between stops (*metres*),
 t = Actual **time** of run between stops (*seconds*),
 α = Acceleration during starting period (m/s^2),
 β = Retardation during braking (m/s^2),
 V_m = Maximum (or crest) **speed** (m/s),
 V_a = Average **speed** ($= D/t$), $*m/s$,
 t_1 = **Time** of acceleration (*seconds*),
 t_3 = **Time** of braking (*seconds*), and
 t_2 = **Time** of free running $= t - (t_1 + t_3)$, in *seconds*.

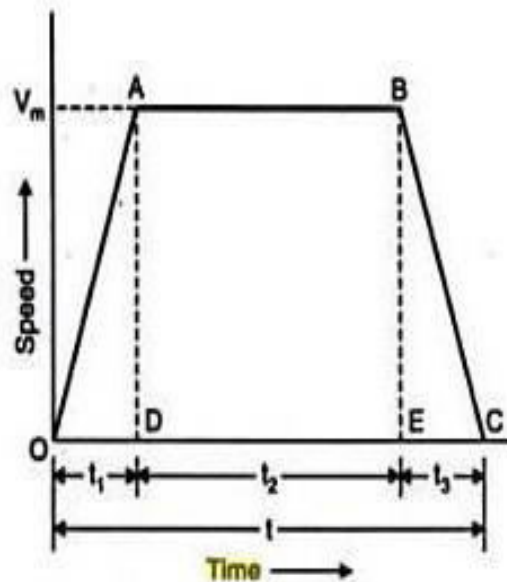

Trapezoidal **speed-time** curve.

From Fig , we have

$$\alpha = \frac{V_m}{t_1} \quad \text{or} \quad t_1 = \frac{V_m}{\alpha} \quad \dots(i)$$

$$\beta = \frac{V_m}{t_3} \quad \text{or} \quad t_3 = \frac{V_m}{\beta} \quad \dots(ii)$$

Since the total distance D between the stops is given by the area of trapezium $OABC$, therefore,

$$\begin{aligned} D &= \text{Area } OABC \\ &= \text{Area } OAD + \text{Area } ABED + \text{Area } BCE \\ &= \frac{1}{2} V_m t_1 + V_m t_2 + \frac{1}{2} V_m t_3 \\ &= \frac{1}{2} V_m t_1 + V_m [t - (t_1 + t_3)] + \frac{1}{2} V_m t_3 \\ &= V_m \left[\frac{t_1}{2} + t - t_1 - t_3 + \frac{t_3}{2} \right] = V_m \left[t - \frac{1}{2} (t_1 + t_3) \right] \end{aligned}$$

or,

$$D = V_m \left[t - \frac{V_m}{2} \left(\frac{1}{\alpha} + \frac{1}{\beta} \right) \right] \quad \text{(From (i), and (ii))}$$

Let,

$$K = \frac{1}{2} \left(\frac{1}{\alpha} + \frac{1}{\beta} \right), \quad \text{or} = \frac{\alpha + \beta}{2\alpha\beta} \quad \dots(1)$$

Substituting the value of K in the above eqn., we get

$$D = V_m(t - KV_m)$$

or,
$$KV_m^2 - V_m t + D = 0 \quad \dots(iii)$$

$$\therefore V_m = \frac{t \pm \sqrt{t^2 - 4KD}}{2K}$$

The +ve sign will not be used, as it will give much higher value of V_m which will not be met with in practice. Therefore, we have

$$V_m = \frac{t - \sqrt{t^2 - 4KD}}{2K} \quad \dots(2)$$

From eqn. (iii), we get

$$KV_m^2 = V_m t - D$$

or,
$$K = \frac{t}{V_m} - \frac{D}{V_m^2} = \frac{D}{V_m^2} \left(V_m \cdot \frac{t}{D} - 1 \right)$$

Now,
$$V_a = \frac{D}{t}$$

$$\therefore K = \frac{D}{V_m^2} \left(\frac{V_m}{V_a} - 1 \right) \quad \dots(3)$$

Obviously, if V_m , V_a and D are given, then value of K and hence of α and β can be found.

QUADRILATERAL SPEED TIME CURVE:

It is a approximation of urban or suburban service runs where short distance are involved. The below figure shows the quadrilateral speed time curve OABC

Let, α = Acceleration during starting period,

β_c = Retardation during coasting period,

β = Retardation during braking,

V_1 = Maximum speed at the end of acceleration,

V_2 = Speed at the end of coasting, and

t = Total time of run.

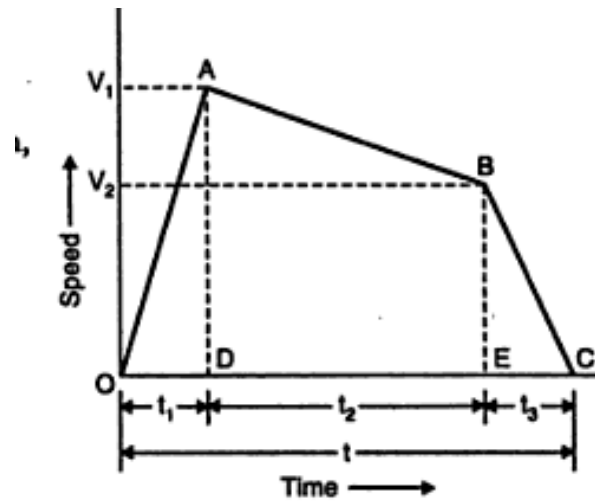

Quadrilateral speed-time curve.

Time of acceleration, $t_1 = \frac{V_1}{\alpha}$

Time of coasting, $t_2 = \frac{V_1 - V_2}{\beta_c}$

Time of braking, $t_3 = \frac{V_2}{\beta}$

Total distance travelled, $D = \text{Area } OABC$
 $= \text{Area } OAD + \text{Area } ABED + \text{Area } BCE$
 $= \frac{1}{2} V_1 t_1 + \left(\frac{V_1 + V_2}{2} \right) t_2 + \frac{1}{2} V_2 t_3$

$$\begin{aligned}
 &= \frac{1}{2} V_1(t_1 + t_2) + \frac{1}{2} V_2(t_2 + t_3) \\
 &= \frac{1}{2} V_1(t - t_3) + \frac{1}{2} V_2(t - t_1) \\
 &= \frac{1}{2} t(V_1 + V_2) - \frac{V_2 t_1}{2} - \frac{V_1 t_3}{2} \\
 &= \frac{1}{2} t(V_1 + V_2) - \frac{1}{2} V_1 V_2 \left(\frac{1}{\alpha} + \frac{1}{\beta} \right)
 \end{aligned}$$

$$\text{or, } D = \frac{1}{2} t(V_1 + V_2) - K V_1 V_2 \quad \dots(4)$$

$$\text{where } K = \frac{1}{2} \left(\frac{1}{\alpha} + \frac{1}{\beta} \right) = \frac{\alpha + \beta}{2\alpha\beta}, \text{ Also } \beta_c = \frac{V_1 - V_2}{t_2}$$

$$\begin{aligned}
 \therefore V_2 &= V_1 - \beta_c t_2 = V_1 - \beta_c (t - t_1 - t_3) \\
 &= V_1 - \beta_c \left(t - \frac{V_1}{\alpha} - \frac{V_2}{\beta} \right)
 \end{aligned}$$

$$\text{or, } V_2 = V_1 - \beta_c \left(t - \frac{V_1}{\alpha} \right) + \beta_c \frac{V_2}{\beta}$$

$$\text{or, } V_2 \left(1 - \frac{\beta_c}{\beta} \right) = V_1 - \beta_c \left(t - \frac{V_1}{\alpha} \right)$$

$$\therefore V_2 = \frac{V_1 - \beta_c \left(t - \frac{V_1}{\alpha} \right)}{\left(1 - \frac{\beta_c}{\beta} \right)} \quad \dots(5)$$

TRACTIVE EFFORT FOR PROPULSION OF TRAIN:

The effective force, necessary to propel the train, at the wheels of locomotive is called the tractive effort.

Total tractive effort required to run a train on track = tractive effort required for linear and angular acceleration + tractive effort to overcome the effect of gravity + tractive effort to overcome the train resistance

$$F_t = F_a \pm F_g + F_r$$

TRACTIVE EFFORT FOR ACCELERATION:

According to laws of dynamic force is required to accelerate the motion of the body and is given by the expression

$$\text{Force} = \text{mass} \times \text{acceleration}$$

Consider a train of weight W tonne being accelerated at α kmphs

The weight of train = $1000 W$ kgf

Mass of train, $m = 1000 W$ kg

$$\text{Acceleration} = \alpha \text{ kmphs} = \alpha \times \frac{1000}{3600} \text{ m/s}^2 = 0.2778 \alpha \text{ m/s}^2$$

Tractive effort required for linear acceleration is

$$F_a = m \alpha = 1000 W \times 0.2778 \alpha = 277.8 \alpha \text{ m/s}^2$$

With the linear acceleration of the train, the rotating parts of the such as wheels and motors also accelerate in an angular direction and therefore the tractive effort required is equal to the arithmetic sum of tractive effort required to have an angular acceleration of rotating parts and tractive effort required to have the linear acceleration. The tractive effort required to have angular acceleration depends upon the individual weight, radius of gyration etc. of the rotating parts requiring angular acceleration. Hence the equivalent accelaerating weight of the train ia taken as W_e which is higher than the dead weight W requiring linear acceleration to consider a tractive effort for the angular acceleration. In practice, W_e is higher than W by 8 to 15%. The normal value lies between 10 to 12 percent.

Hence tractive effort required for acceleration = $277.8 W_e \alpha$ newtons

TRACTIVE EFFORT FOR OVERCOMING THE EFFECT OF GRAVITY:

When a train is on a slope, a force of gravity equal to the component of dead weight along the slope acts on the train and tends to cause its motion down the gradient or slope.

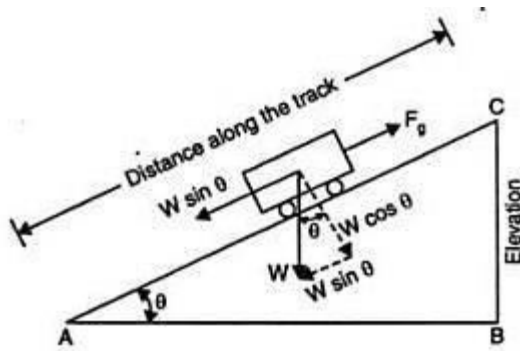

Hence force due to gradient is

$$F_g = 1000 W \sin \theta \text{ kg} \text{-----(i)}$$

But in railway work gradient is expressed as rise in metres in a track distance of 100 metres and is denoted as percentage gradient ($G\%$)

$$G = \sin \theta \times 100$$

$$\Rightarrow \sin \theta = \frac{G}{100}$$

Substituting above value in eqn(i)

$$F_g = 1000 W \frac{G}{100}$$

$$= 10 WG \text{ kg}$$

$$= 10 \text{ WG} \times 9.81$$

$$= 98.1 \text{ WG newtons}$$

When a train is up a gradient, the tractive effort will be required to balance this force due to gradient but while going down the gradient the force will add to the tractive effort.

TRACTIVE EFFORT FOR OVERCOMING TRAIN RESISTANCE:

Train resistance consists of all the forces resisting the motion of the train when it is running at uniform speed on a straight and level track. Under these circumstances the whole of the energy output from the driving axles is expended against train resistance. Train resistance is due to (i) the friction at the various parts of the rolling stock. (ii) friction at the track and (iii) air resistance. The first two components constitute the mechanical resistance component of train resistance. For a normal train the value of specific resistance has been 40 to 70 newtons/tonne.

Tractive effort required to overcome the train resistance is

$$F_r = W \times r \text{ newtons}$$

$$\text{Total tractive effort required, } F_t = F_a \pm F_g + F_r$$

$$= 277.8 W_e \alpha \pm 98.1 \text{ WG} + W_r$$

+ve sign for motion up the gradient

-ve Sign for motion down the gradient

FACTORS AFFECTING SCHEDULE SPEED:

The schedule speed of a given train when running on a given service is affected by the following factors:

- Acceleration and braking retardation
- Maximum or crest speed
- Duration of stop

EFFECT OF ACCELERATION AND BRAKING RETARDATION:

For a given run and with fixed crest speed the increase in a acceleration will result in decrease in actual time of run and therefore increase in schedule speed similarly increase in braking retardation will effect the schedule speed . Variation in acceleration and retardation will have more effect on schedule speed in case of shorter distance run in comparision to longer distance run.

EFFECT OF MAXIMUM SPEED

For a constant distance run and with fixed acceleration and retardation actual time of run will decrease and therefore schedule speed will increase with the increase in crest speed .the effect of variation in crest speed on schedule speed is considerable in case of long distance run.

EFFECT OF DURATION OF STOP:

For a given avg speed the schedule speed will increase by reducing the duration of stop .The variation in duration of stop will affect the schedule speed more in case of shorter distance run as compared to longer distance run.